



WITTENSTEIN

alpha

Hygienic Design HDP⁺, HDV, axenia value

hygienic
reliable
resistant



© 2025 by WITTENSTEIN alpha GmbH

All technical specifications were correct at the time of going to print. We are continually developing our products and therefore reserve the right to make modifications. This documentation is subject to occasional errors. Please appreciate that legal claims cannot be asserted as a result of incorrect specifications, illustrations or descriptions. The text, photos, technical drawings and any other illustrations printed in this publication are protected property of WITTENSTEIN alpha GmbH.

Further use of this material in printed or electronic format requires approval from WITTENSTEIN alpha GmbH.

Any form of duplication, translation, editing, transfer to microfilm or storage on electronic systems is not permitted without express permission from WITTENSTEIN alpha GmbH.

Content

WITTENSTEIN alpha	4
More than 40 years of innovation	4
Hygienic Design	8
Product range and applications	8
Low backlash planetary gearboxes	14
HDV	14
HDV 015 MF	16
HDV 025 MF	18
HDV 035 MF	20
HDP+	22
HDP+ 010 MA	24
HDP+ 025 MA	26
axenia value servo actuators	28
AVF 1	30
AVF 2	32
AVF 3	34
Ordering code	36
Ordering code – HDV and HDP+	36
Ordering code – axenia value	37
Ordering code – axenia value cables	38
Mounting kit	39
Product portfolio & company	40
cyber® dynamic line	40
Gearbox overview	42
Engineering tools	48
Services	50
WITTENSTEIN Group	52
Information	54
Servo actuators project planning	54
Glossary	56

YOUR WORLD IS OUR DRIVE.

FOR MORE THAN 40 YEARS.



SP



LP



Linear systems



TPM+



High Performance Linear System



alpha Value Line

1983

1994

1996

1999

2002

2004

2006

2007

2011

2013

2015

TP



cymex®
sizing software



XP+ / TP+ / SP+ / LP+



TPK+ / SPK+ /
HG+ / SK+ / TK+



HDV
Hygienic Design



PERFORMANCE

Performance where it counts:
High torque, outstanding precision and high power density – essential for our products and systems.

FUTURE PROOF

We live processes:
Only those who know the exact details of customer processes and requirements are in a position to develop solutions that offer added value in the short and long term.

SCALABILITY

You never make compromises:
Whatever the performance area – we offer solutions that grow with your requirements.



WITTENSTEIN

alpha

It is good to know today what will be needed tomorrow. Applying it in practice is even better. We develop technology that shapes the future – ENGINEERING FUTURE SOLUTIONS.

EFFICIENCY

We like it „lean“:
We offer products and systems that are energy-efficient and require minimal installation space in machines.

AVAILABILITY

You need reliability:
We have the widest range of products on the market and can implement your application „just in time“.

CONNECTIVITY

We think in terms of interfaces:
All of our systems can be integrated in a wide range of peripherals.



DP⁺ for Delta robots



INIRA[®]



alpha Linear Systems



alpha Basic Line



cynapse[®]



cymex[®] select

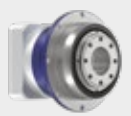

NTP

2016

cymex[®] 5



SIZING ASSISTANT



V-Drive Family



2018

premo[®]



2019

CAD POINT



2022

WITTENSTEIN Service Portal



2023

axenia value



WITTENSTEIN alpha on all axes

Complete drive solutions under one roof

We offer the best solutions for almost every application. In addition to gearboxes, our product portfolio includes a wide range of drive solutions with linear systems and servo actuators. Adapted accessories such as couplings and shrink disks round off the product portfolio.

The diagrams below provide a quick overview of our product portfolio for a wide variety of requirements and applications:

Planetary gearboxes

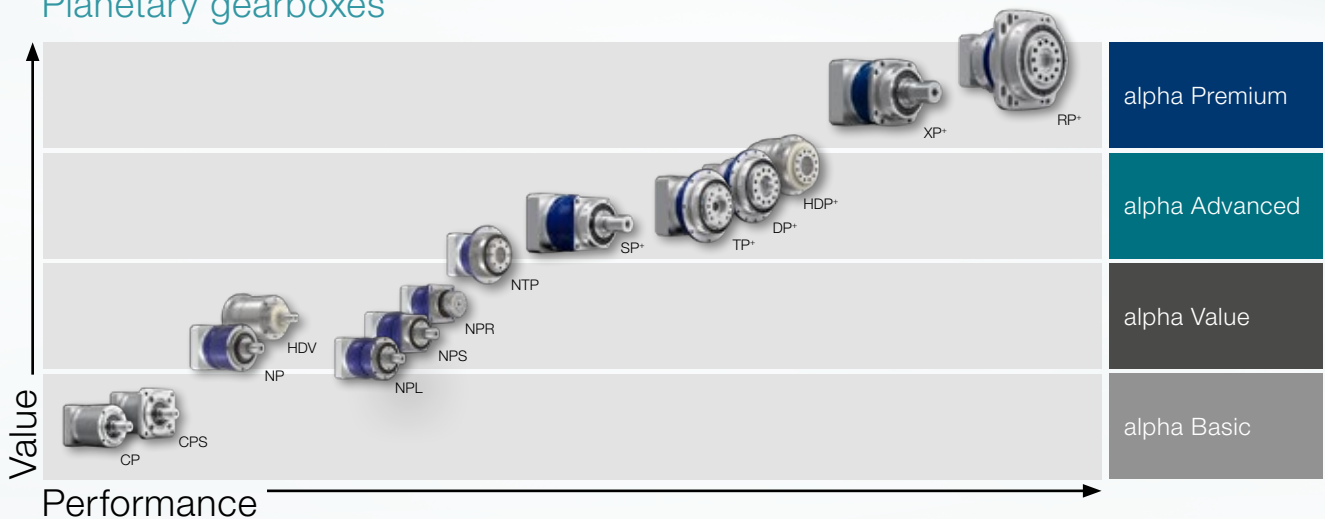

Hypoid, bevel and worm gearboxes



Know-how in every sector

Our solutions range from high-precision axes in manufacturing systems to packaging machines that must operate with maximum productivity in the smallest installation space. Overview:

- Machine tools and production technology
- Food and packaging machines
- Wood working machinery
- Printing and paper machines
- Robotics and automation

Linear systems

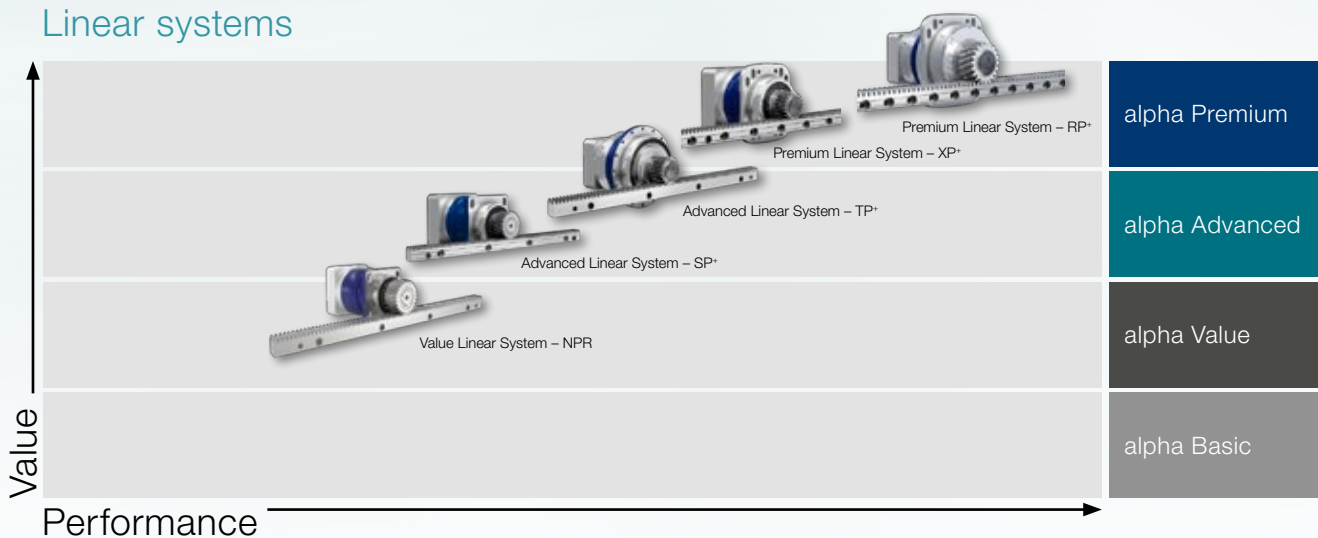

Servo actuators

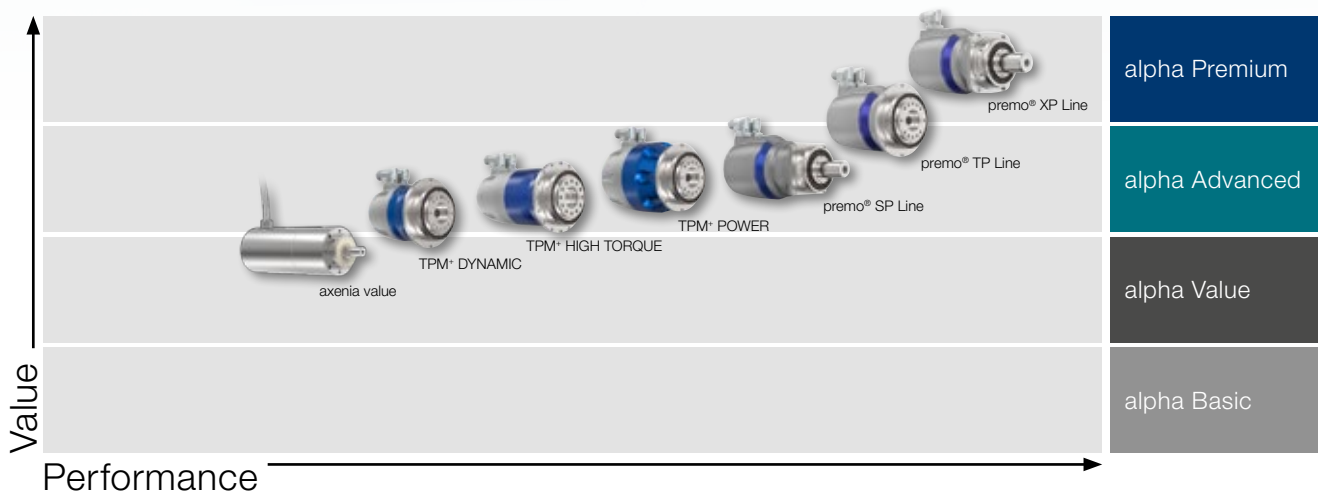

Hygienic Design

Consistent hygienic design for best possible process integration and reliable cleaning with new design freedom: We offer corrosion-resistant products and holistic solutions in a hygienic design based on our many years of experience in drive solutions in hygienic systems.

Our portfolio for process-integrated use includes numerous variants and ranges from planetary gearboxes to compact servo actuators.

As a member of EHEDG (European Hygienic Engineering & Design Group)[®], we are pioneers in this field and develop our products in accordance with EHEDG guidelines[®]. We enable our customers to always meet the highest demands with maximum efficiency with their machines.

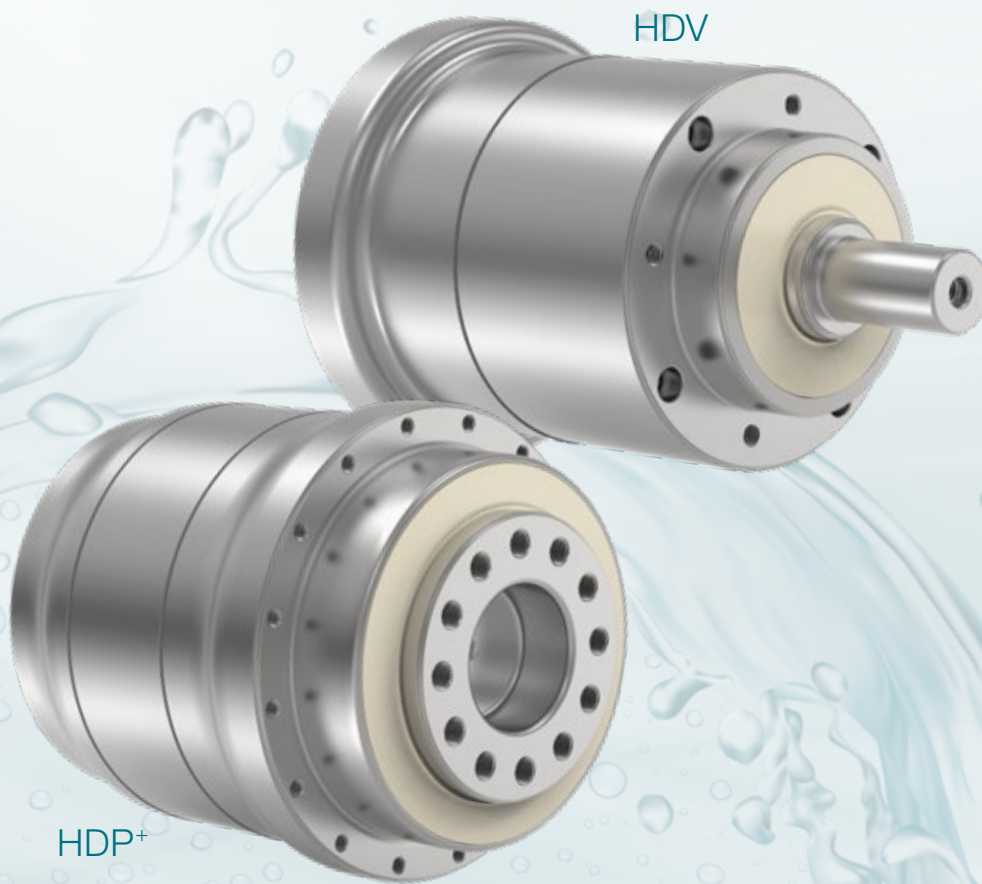

* in preparation
** max. 30 bar



HDP+ planetary gearbox with output flange



HDV planetary gearbox with output shaft

axenia value



Open hygienic design structures

Until now, conventional enclosures have dominated in hygienic design. Now, a fully hygienic drive that goes beyond stainless steel⁽¹⁾ gives new design freedom, in line with current guidelines.

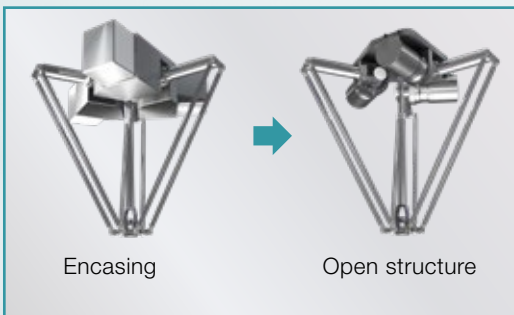

Benefits for system manufacturers

- Compliance with legal requirements
- fewer single parts for simpler production and assembly
- More compact design
- Innovation / competitive edge

Benefits for operators

- Reduction in total cost of ownership (TCO)⁽¹⁾ thanks to easier and shorter cleaning (CIP/SIP-ready)⁽¹⁾
- Extended service life of drives, since, unlike in enclosures, no accumulated heat occurs
- Quick and easy removal
- Higher food safety, as dirt cannot accumulate and moisture cannot form without an enclosure

⁽¹⁾ See glossary for basic knowledge and definitions of terms related to hygienic design

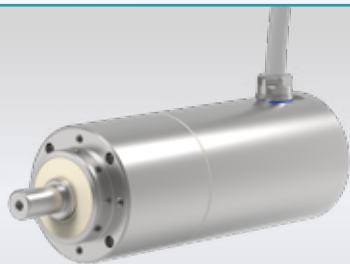

axenia value servo actuator with single cable



Member of EHEDG⁽¹⁾

Built to protect

Hygienic Design



Wide range of possible applications



Food industry

Particularly in the processing and primary packaging of perishable foods such as meat and fish, hygienic processes are mandatory and prescribed by a wide range of regulations. Open machine concepts in hygienic design⁰ reduce the cleaning effort and contamination risks.

Typical applications

- Cutting machinery (slicers)
- Forming, filling and dosing systems
- Conveyors and feed processes
- Sealing and closure processes



Pharmaceutical industry

“Good Manufacturing Practice” (GMP) for pharmaceuticals stands for high demands on quality in production and packaging processes via a wide range of international regulations. Whether creams in tubes and jars, capsules in blisters, or vaccines in glass vials - it is a simple task for your drive train, thanks to the hygienic stainless steel surfaces and advanced seals of our gearboxes.

Typical applications

- Stirring and mixing machines
- Forming, filling and dosing systems
- Conveyors and feed processes
- Sealing and closure processes



Cosmetics industry

As in the food and pharmaceutical industries, consumer safety is also the key consideration in manufacturing and primary packaging of cosmetic products.

Typical applications

- Stirring and mixing machines
- Dosing and filling systems
- Sealing and closure processes

⁰ See glossary for basic knowledge and definitions of terms related to hygienic design

Applications and benefits

DRIVE HYGIENICALLY SAFE

Fast, efficient and reliable cleaning paired with drive durability is a key factor in hygienic automation.

Our solutions meet the requirements of various production areas (here using the example of a fish processing plant). In this context, hygienic design⁽¹⁾ stands for open machine concepts, minimum contamination risk and a competitive edge for the system manufacturer.



premo®

SP+

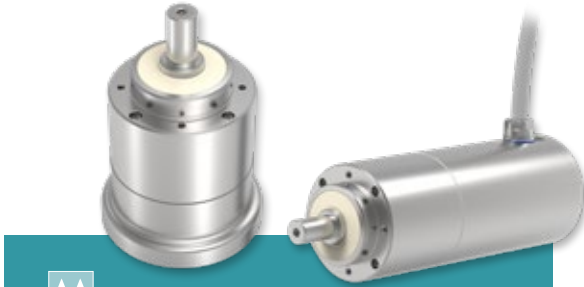

Sealing

HDV / AVF

Thanks to the highly compact planetary gearboxes (HDV) and actuators axenia value (AVF), cleaning cycles are shortened and the machines are available longer. The high protection class of IP69K⁽¹⁾ and the deadspace-free design give machine builders completely new freedom when setting up systems that meet the highest demands for hygienic and sterile production.

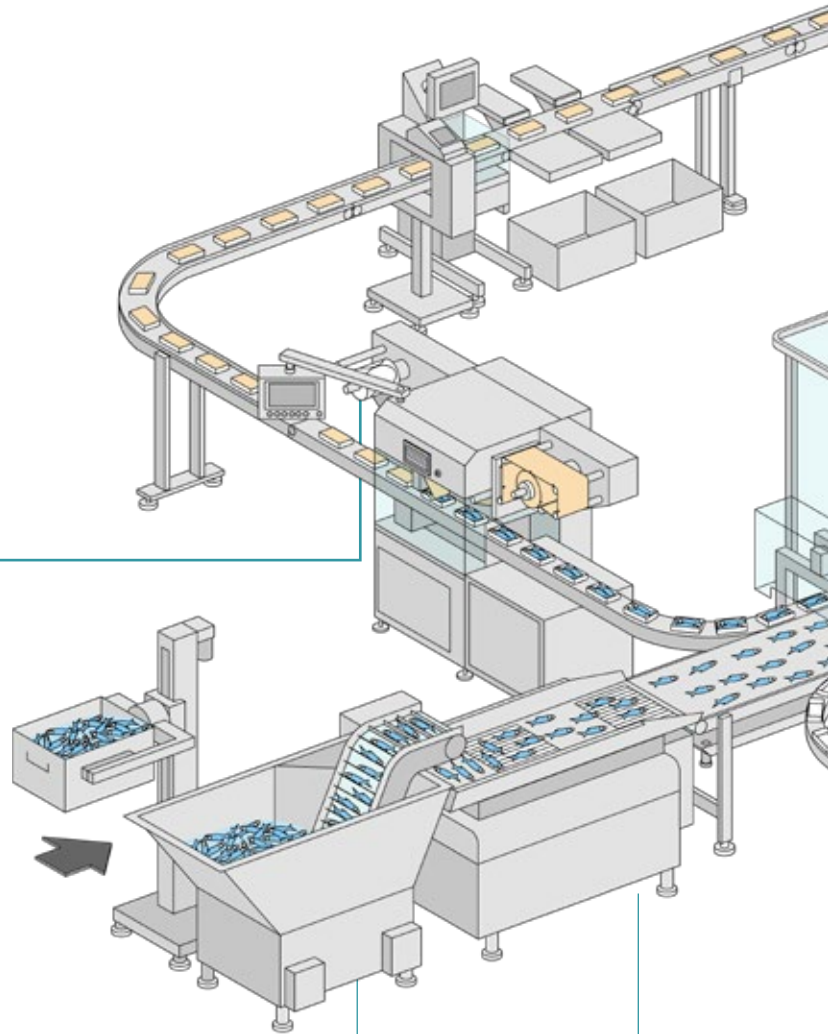

VT+



HG+

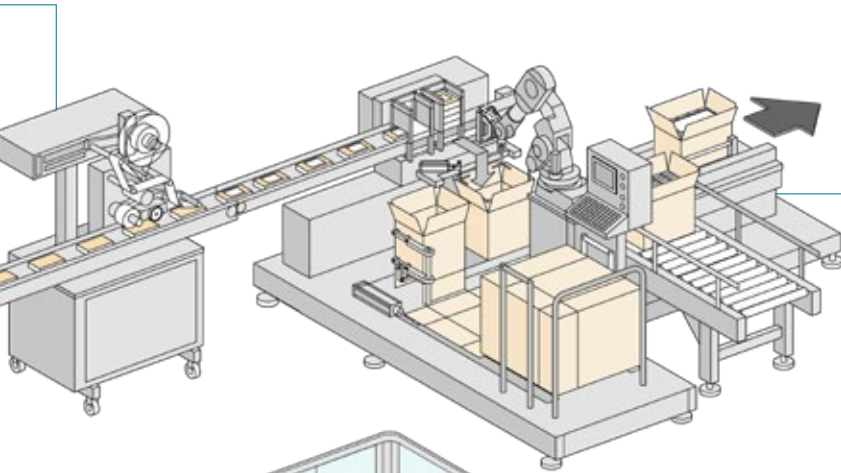

NP

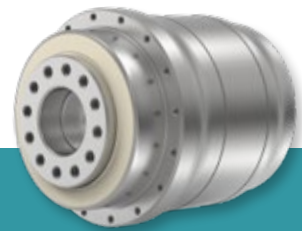
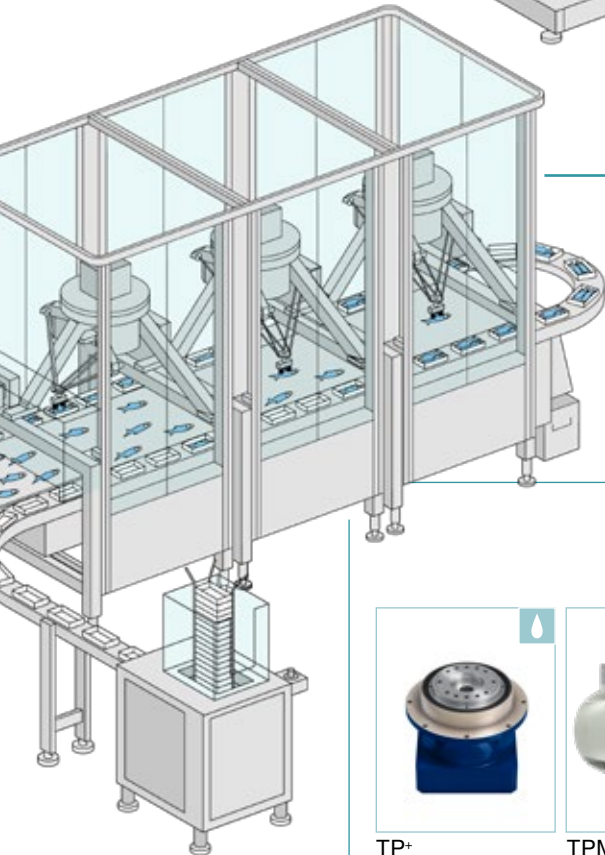

Pick&Place robot

HDP+

The highly compact, low-backlash HDP+ planetary gearboxes are specially designed for handling modules and delta kinematics. They offer maximum safety, especially in food processing. The new concept gives the designer completely new freedom to build systems with the highest standards of hygienic and sterile production.





TP+



TPM+

CLASSIFICATION AS PER DIN EN 1672-2⁽¹⁾

-  Standard application in dry area (not food sector)
-  Application in wet and humid environments (spray area) - process-integral
-  Applications in wet areas, including high-pressure cleaning as well as contact with cleaning agents and chemicals (food sector) – process-integrated



SP+

⁽¹⁾ See glossary for basic knowledge and definitions of terms related to hygienic design

HDV - Reliably clean



Aseptic, highly dynamic and with precise positioning – like our other Hygienic Design series, the HDV has been developed in accordance with EHEDG guidelines⁽¹⁾ and meets the strict hygiene requirements of production and packaging systems. The gearbox in Hygienic Design⁽¹⁾ not only provides the best possible protection against contamination-related product and process risks. It also ensures maximum system availability and productivity.

Product highlights

- New design freedoms:**
 Direct process integration opens up new design options in food/wet applications.
- Resistance:**
 Resistant against chemical agents and disinfectants, tested according to ECOLAB test method 40-1.
- Cleaning:**
 Fast, efficient and reliable cleaning, also suitable for CIP/SIP processes.
- Maximum impermeability:**
 Tested to IP69K (max. 30 bar) following DIN EN 60529.

The HDV compared to the industry standard

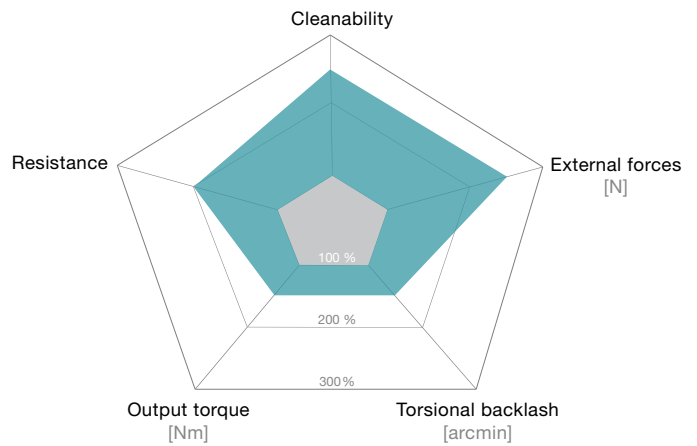

- HDV
- Industry standard

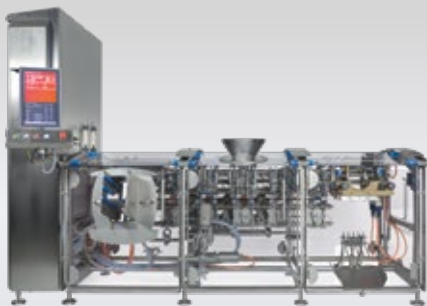

Proven solution for your system

Thanks to their flexible design, the hygienic forming, filling and sealing machines from baumannpacking allow quick format changes and can be cleaned with up to 20 bar.

© baumannpacking

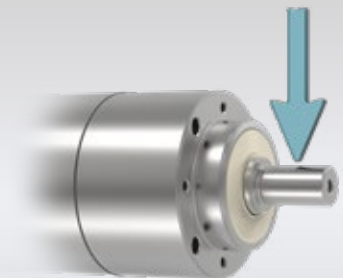

HIGH FORCES (MT version)

With its reinforced output bearing, HDV HIGH FORCES offers up to 6 times higher tilting moment as well as increased axial and lateral force. This makes it a universally usable gearbox for a wide range of applications.



Maximum impermeability

Protection class IP69K⁰⁾ (max. 30 bar) with 3-fold sealing concept for maximum safety

Hygienic housing design

Housings made of smooth-rolled stainless steel 1.4404 / AISI 316L⁰⁾ ($R_a \leq 0.8 \mu\text{m}$)⁰⁾ without deadspaces and with large radii; O-ring shape according to DIN 11864⁰⁾

Safety

Food-grade lubrication (NSF, Kosher and Halal certificates)⁰⁾; FDA-certified materials⁰⁾

Flexibility

Connection to all conventional stainless steel motors (options available for B14⁰⁾ mounting)

System concept with high compactness

The HDV is also available with servo motor as **axenia value** complete unit. Details from page 28.

⁰⁾ See glossary for basic knowledge and definitions of terms related to hygienic design

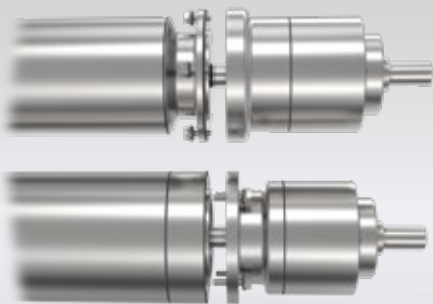

Flexible motor mounting

B5 mounting: Direct screw-fitting by means of through holes in the motor flange into the input flange of the gearbox.

B14 mounting: With a single hygienic interface, the drive unit is screw-fitted from the side of the gearbox.

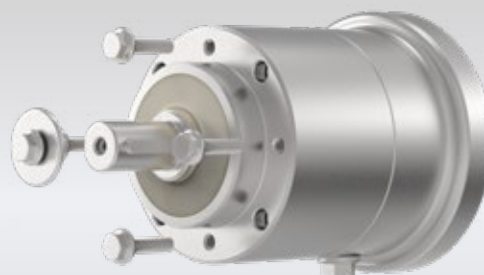

Optional mounting kit

We have developed special mounting kits for our Hygienic Design⁰⁾ gearboxes of the HDV series. They guarantee hygienic connection to the application with the highest possible process reliability. For details, see page 39.

HDV 015 MF 1-/2-stage

			1-stage				2-stage							
Ratio	i		4	5	7	10	16	20	25	35	50	70	100	
Max. torque ^{a) b) e)}	T_{2a}	Nm	51	51	51	46	51	51	51	51	51	51	46	
		in.lb	451	451	451	407	451	451	451	451	451	451	407	
Max. acceleration torque ^{e)} (max. 1000 cycles per hour)	T_{2B}	Nm	32	32	32	29	32	32	32	32	32	32	29	
		in.lb	283	283	283	257	283	283	283	283	283	283	257	
Emergency stop torque ^{a) b) e)} (permitted 1000 times during the service life of the gearbox)	T_{2Not}	Nm	75	75	75	75	75	75	75	75	75	75	75	
		in.lb	664	664	664	664	664	664	664	664	664	664	664	
Permitted average input speed ^{d)} (at T_{2a} and 20 °C ambient temperature)	n_{1N}	rpm	3000	3000	3000	3000	3700	3700	3700	3700	3700	3700	3700	
Max. input speed	n_{1Max}	rpm	6000	6000	6000	6000	6000	6000	6000	6000	6000	6000	6000	
Mean no load running torque ^{b)} (at $n_1=3000$ rpm and 20 °C gearbox temperature)	T_{012}	Nm	0.15	0.15	0.15	0.15	0.15	0.15	0.15	0.15	0.15	0.15	0.15	
		in.lb	1.3	1.3	1.3	1.3	1.3	1.3	1.3	1.3	1.3	1.3	1.3	
Max. backlash	j_t	arcmin	≤ 10				≤ 15							
Torsional rigidity ^{b)}	C_{t21}	Nm/arcmin	2.3	2.3	2.3	2	2.3	2.3	2.3	2.3	2.3	2.3	2	
		in.lb/arcmin	20	20	20	18	20	20	20	20	20	20	18	
Max. axial force ^{c)} (Standard / HIGH FORCES)	F_{2AMax}	N	500 / 1000				500 / 1000							
		lb _f	113 / 225				113 / 225							
Max. lateral force ^{c)} (Standard / HIGH FORCES)	F_{2QMax}	N	350 / 1600				350 / 1600							
		lb _f	79 / 360				79 / 360							
Max. tilting moment (Standard / HIGH FORCES)	M_{2KMax}	Nm	20 / 105				20 / 105							
		in.lb	177 / 929				177 / 929							
Efficiency at full load	η	%	97				95							
Service life	L_h	h	> 20000				> 20000							
Weight (incl. standard adapter plate)	m	kg	3.2				3.8							
		lb _m	7.1				8.4							
Operating noise (at reference ratio and reference speed – ratio-specific values available in cymex [®])	L_{PA}	dB(A)	≤ 60				≤ 60							
Max. permitted housing temperature		°C	+90				+90							
		°F	+194				+194							
Ambient temperature		°C	-25 to +40				-25 to +40							
		°F	-13 to +104				-13 to +104							
Lubrication			Lubricated for life											
Direction of rotation			In- and output same direction											
Protection class ^{g)}			IP69K (max. 30 bar)											
Mass moment of inertia (relates to the drive) Clamping hub diameter [mm]	C	14	J_1	kgcm ²	0.18	0.17	0.15	0.15	0.17	0.16	0.16	0.15	0.15	0.15
				10 ⁻³ in.lb.s ²	0.16	0.15	0.13	0.13	0.15	0.14	0.14	0.13	0.13	0.13

For a more detailed design, please use our cymex[®] design software – www.wittenstein-cymex.com

^{a)} Valid for torque transmission only

^{b)} Valid for standard clamping hub diameter

^{c)} Refers to center of the output shaft or flange

^{d)} Please reduce input speed at higher ambient temperatures

^{e)} Valid for: Smooth shaft

^{f)} Applies at standstill, for details see operating instructions

HDV 025 MF 1-/2-stage

			1-stage				2-stage								
Ratio	i		4	5	7	10	16	20	25	35	50	70	100		
Max. torque ^{a) b) e)}	T_{2a}	Nm	128	128	128	115	128	128	128	128	128	128	115		
		in.lb	1133	1133	1133	1018	1133	1133	1133	1133	1133	1133	1018		
Max. acceleration torque ^{e)} (max. 1000 cycles per hour)	T_{2B}	Nm	80	80	80	72	80	80	80	80	80	80	72		
		in.lb	708	708	708	637	708	708	708	708	708	708	637		
Emergency stop torque ^{a) b) e)} (permitted 1000 times during the service life of the gearbox)	T_{2Not}	Nm	190	190	190	190	190	190	190	190	190	190	190		
		in.lb	1682	1682	1682	1682	1682	1682	1682	1682	1682	1682	1682		
Permitted average input speed ^{d)} (at T_{2a} and 20 °C ambient temperature)	n_{1N}	rpm	2700	2700	2700	2700	3400	3400	3400	3400	3400	3400	3400		
Max. input speed	n_{1Max}	rpm	6000	6000	6000	6000	6000	6000	6000	6000	6000	6000	6000		
Mean no load running torque ^{b)} (at $n_1=3000$ rpm and 20 °C gearbox temperature)	T_{012}	Nm	0.3	0.3	0.3	0.3	0.3	0.3	0.3	0.3	0.3	0.3	0.3		
		in.lb	2.7	2.7	2.7	2.7	2.7	2.7	2.7	2.7	2.7	2.7	2.7		
Max. backlash	j_t	arcmin	≤ 10				≤ 15								
Torsional rigidity ^{b)}	C_{t21}	Nm/arcmin	7.5	7.5	7.5	5.5	7.5	7.5	7.5	7.5	7.5	7.5	5.5		
		in.lb/arcmin	66	66	66	49	66	66	66	66	66	66	49		
Max. axial force ^{c)} (Standard / HIGH FORCES)	F_{2AMax}	N	500 / 1500				500 / 1500								
		lb _f	113 / 338				113 / 338								
Max. lateral force ^{c)} (Standard / HIGH FORCES)	F_{2GMMax}	N	500 / 2500				500 / 2500								
		lb _f	113 / 563				113 / 563								
Max. tilting moment (Standard / HIGH FORCES)	M_{2KMax}	Nm	31 / 185				31 / 185								
		in.lb	274 / 1637				274 / 1637								
Efficiency at full load	η	%	97				95								
Service life	L_h	h	> 20000				> 20000								
Weight (incl. standard adapter plate)	m	kg	5.2				6.5								
		lb _m	11				14								
Operating noise (at reference ratio and reference speed – ratio-specific values available in cymex [®])	L_{PA}	dB(A)	≤ 63				≤ 63								
Max. permitted housing temperature		°C	+90				+90								
		°F	+194				+194								
Ambient temperature		°C	-25 to +40				-25 to +40								
		°F	-13 to +104				-13 to +104								
Lubrication			Lubricated for life												
Direction of rotation			In- and output same direction												
Protection class ^{g)}			IP69K (max. 30 bar)												
Mass moment of inertia (relates to the drive) Clamping hub diameter [mm]	E	19	J_1	kgcm ²	0.63	0.54	0.52	0.46	0.6	0.52	0.54	0.5	0.52	0.52	0.46
				10 ⁻³ in.lb.s ²	0.56	0.48	0.46	0.41	0.53	0.46	0.48	0.44	0.46	0.46	0.41

For a more detailed design, please use our cymex[®] design software – www.wittenstein-cymex.com

^{a)} Valid for torque transmission only

^{b)} Valid for standard clamping hub diameter

^{c)} Refers to center of the output shaft or flange

^{d)} Please reduce input speed at higher ambient temperatures

^{e)} Valid for: Smooth shaft

^{f)} Applies at standstill, for details see operating instructions

1-stage

up to 19⁴⁾ (E⁵⁾
clamping hub
diameter

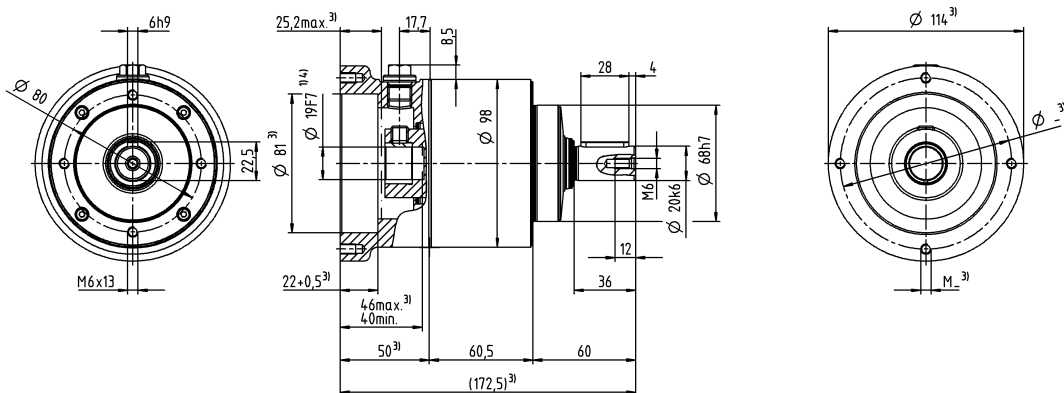

2-stage

up to 19⁴⁾ (E⁵⁾
clamping hub
diameter

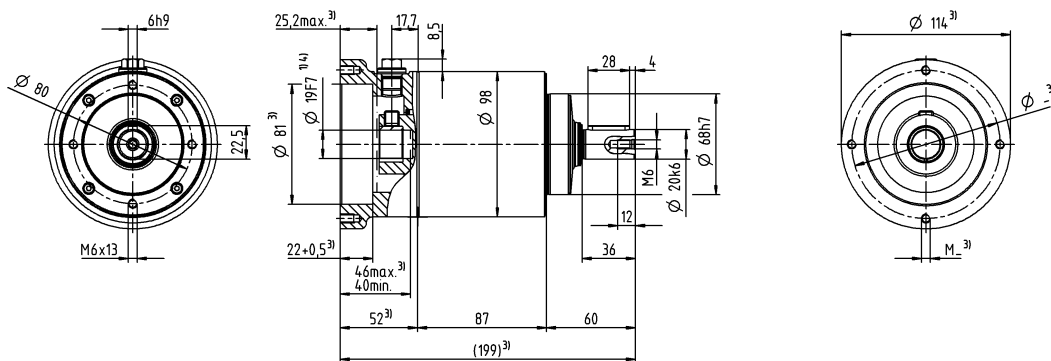

Motor shaft diameter [mm]

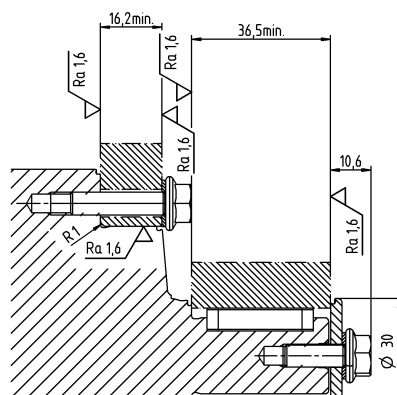

Other output variants

Smooth shaft

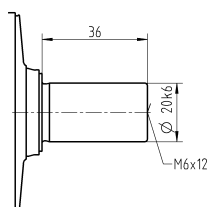

Mounting accessories:

Mounting kit comprising stainless steel screws, washers, seals and O-rings available as an option.

Non-tolerated dimensions are nominal dimensions

¹⁾ Check motor shaft fit

²⁾ Min. / Max. permissible motor shaft length

Longer motor shafts are possible, please contact alpha

³⁾ The dimensions depend on the motor

⁴⁾ Smaller motor shaft diameter is compensated by a bushing with a minimum wall thickness of 1 mm

⁵⁾ Standard clamping hub diameter

HDV 035 MF 1-/2-stage

			1-stage				2-stage								
Ratio	i		4	5	7	10	16	20	25	35	50	70	100		
Max. torque ^{a) b) e)}	T_{2a}	Nm	320	320	320	288	320	320	320	320	320	320	288		
		in.lb	2832	2832	2832	2549	2832	2832	2832	2832	2832	2832	2832	2549	
Max. acceleration torque ^{e)} (max. 1000 cycles per hour)	T_{2B}	Nm	200	200	200	180	200	200	200	200	200	200	180		
		in.lb	1770	1770	1770	1593	1770	1770	1770	1770	1770	1770	1770	1593	
Emergency stop torque ^{a) b) e)} (permitted 1000 times during the service life of the gearbox)	T_{2Not}	Nm	480	480	480	480	480	480	480	480	480	480	480		
		in.lb	4248	4248	4248	4248	4248	4248	4248	4248	4248	4248	4248	4248	
Permitted average input speed ^{d)} (at T_{2a} and 20 °C ambient temperature)	n_{1N}	rpm	2000	2000	2000	2000	2600	2600	2600	2600	2600	2600	2600		
Max. input speed	n_{1Max}	rpm	4800	4800	4800	4800	4800	4800	4800	4800	4800	4800	4800		
Mean no load running torque ^{b)} (at $n_1=3000$ rpm and 20 °C gearbox temperature)	$T_{0/2}$	Nm	0.5	0.5	0.5	0.5	0.5	0.5	0.5	0.5	0.5	0.5	0.5		
		in.lb	4.4	4.4	4.4	4.4	4.4	4.4	4.4	4.4	4.4	4.4	4.4	4.4	
Max. backlash	j_t	arcmin	≤ 10				≤ 15								
Torsional rigidity ^{b)}	C_{21}	Nm/arcmin	24	24	24	22	24	24	24	24	24	24	22		
		in.lb/arcmin	212	212	212	194	212	212	212	212	212	212	194		
Max. axial force ^{c)} (Standard / HIGH FORCES)	F_{2AMax}	N	1700 / 3000				1700 / 3000								
		lb _f	383 / 675				383 / 675								
Max. lateral force ^{c)} (Standard / HIGH FORCES)	F_{2GMMax}	N	1200 / 4250				1200 / 4250								
		lb _f	270 / 956				270 / 956								
Max. tilting moment (Standard / HIGH FORCES)	M_{2KMax}	Nm	95 / 407				95 / 407								
		in.lb	841 / 3602				841 / 3602								
Efficiency at full load	η	%	97				95								
Service life	L_h	h	> 20000				> 20000								
Weight (incl. standard adapter plate)	m	kg	13.6				16.6								
		lb _m	30				37								
Operating noise (at reference ratio and reference speed – ratio-specific values available in cymex [®])	L_{PA}	dB(A)	≤ 68				≤ 68								
			+90				+90								
Max. permitted housing temperature		°C	+90				+90								
		°F	+194				+194								
Ambient temperature		°C	-25 to +40				-25 to +40								
		°F	-13 to +104				-13 to +104								
Lubrication			Lubricated for life												
Direction of rotation			In- and output same direction												
Protection class ^{g)}			IP69K (max. 30 bar)												
Mass moment of inertia (relates to the drive) Clamping hub diameter [mm]	G	24	J_1	kgcm ²	2.6	2.3	2	1.8	2.3	2.1	2.1	1.9	1.8	1.8	1.8
				10 ⁻³ in.lb.s ²	2.3	2	1.8	1.6	2	1.9	1.9	1.7	1.6	1.6	1.6

For a more detailed design, please use our cymex[®] design software – www.wittenstein-cymex.com

^{a)} Valid for torque transmission only

^{b)} Valid for standard clamping hub diameter

^{c)} Refers to center of the output shaft or flange

^{d)} Please reduce input speed at higher ambient temperatures

^{e)} Valid for: Smooth shaft

^{f)} Applies at standstill, for details see operating instructions

1-stage

up to 24⁴⁾ (G)⁵⁾
clamping hub
diameter

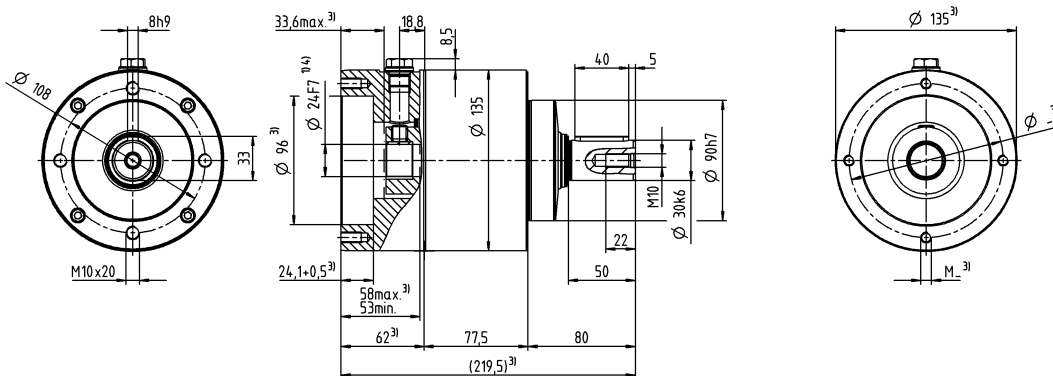

2-stage

Motor shaft diameter [mm]

up to 24⁴⁾ (G)⁵⁾
clamping hub
diameter

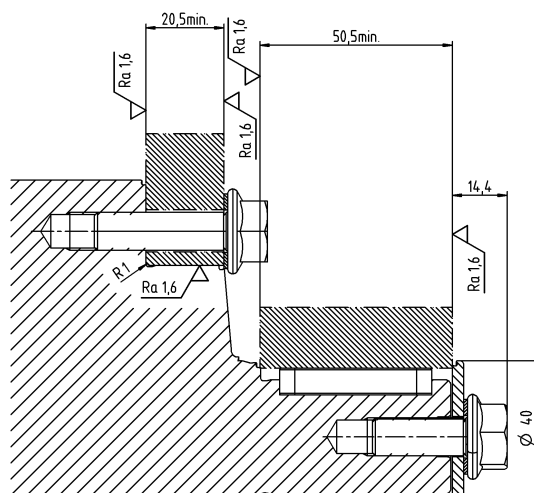
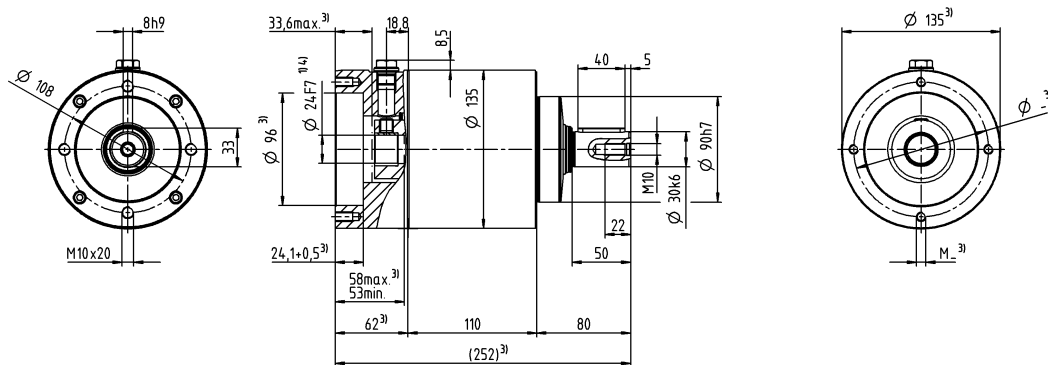

Other output variants

Smooth shaft

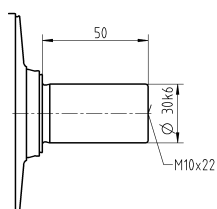

Mounting accessories:

Mounting kit comprising stainless steel screws, washers, seals and O-rings available as an option.

Non-tolerated dimensions are nominal dimensions

¹⁾ Check motor shaft fit

²⁾ Min. / Max. permissible motor shaft length

Longer motor shafts are possible, please contact alpha

³⁾ The dimensions depend on the motor

⁴⁾ Smaller motor shaft diameter is compensated

by a bushing with a minimum wall thickness of 1 mm

⁵⁾ Standard clamping hub diameter

HDP+ – Cleanliness guaranteed



Aseptic, highly dynamic and outstanding positioning accuracy: The HDP+ planetary gearbox meets the strict hygiene requirements of production and packaging facilities. The Hygienic Design[®] gearbox ensures the best possible protection against contamination-related product and process risks as well as maximum availability and productivity of systems – from simple food processing to highly complex delta robotics.

Product highlights

- **Positioning accuracy:**
Minimal backlash and extreme torsional rigidity ensure maximum positioning accuracy.
- **New design freedoms:**
Possibility of direct process integration in the food/wet applications.
- **Resistance:**
Resistant to dry cleaning agents and disinfectants, tested according to ECOLAB Test Method 40-1.
- **Cleaning:**
Fast, efficient and reliable cleaning, also suitable for CIP/SIP processes.
- **Consistent high performance:**
Constant backlash throughout the service life of the gearbox ensures a consistently high performance.
- **Maximum impermeability:**
Tested to IP69K (max. 30 bar).

The HDP+ compared to the industry standard

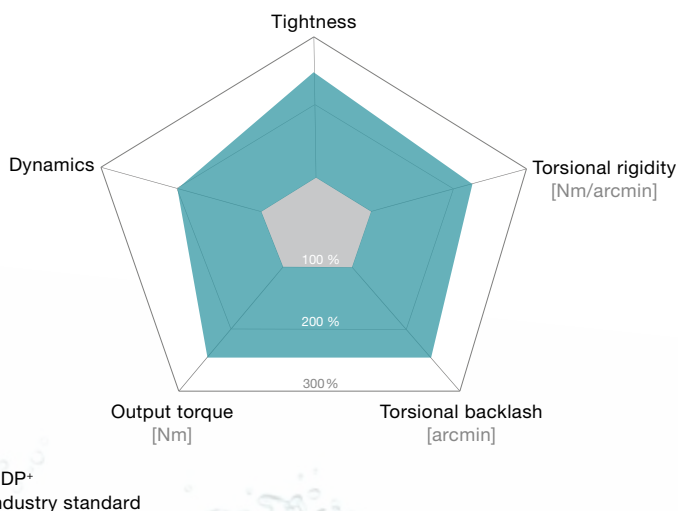

Powerful in practice

Use in hygienic forming, filling and sealing machines for maximum freedom and productivity. The consistently hygienically oriented range of AGILIS tubular bag machines from baumannpacking ensure single-lane output of up to 250 bags per minute. Thanks to the open machine design, cleaning is quick, easy and reliable.

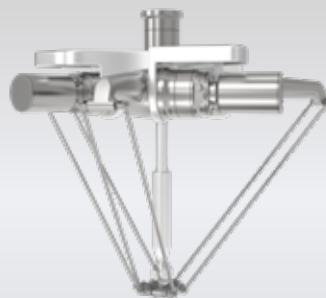

Optimal for delta robotics

In addition to a wide variety of applications in the food, pharmaceutical and cosmetics sectors, the HDP+ is particularly suitable for delta robotics drives. The sealing system of the well-known DP+ gearbox, which is optimized for short-cycle motion profiles, and the oil fill quantity adapted for horizontal mounting position form the foundation for open and hygienic delta kinematics.

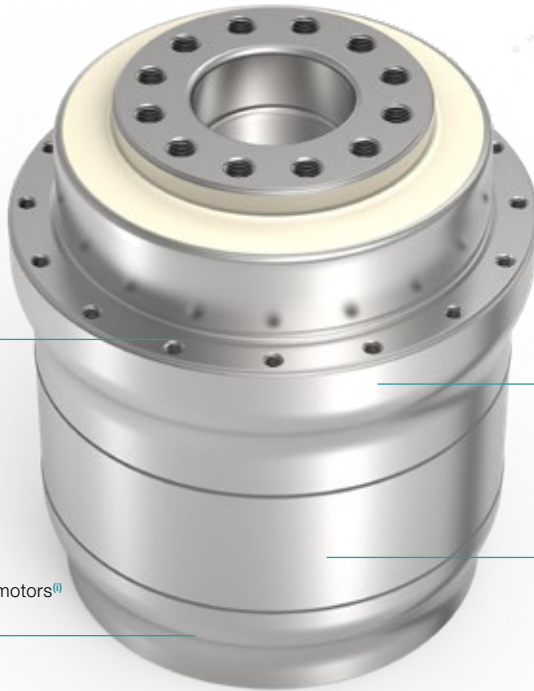
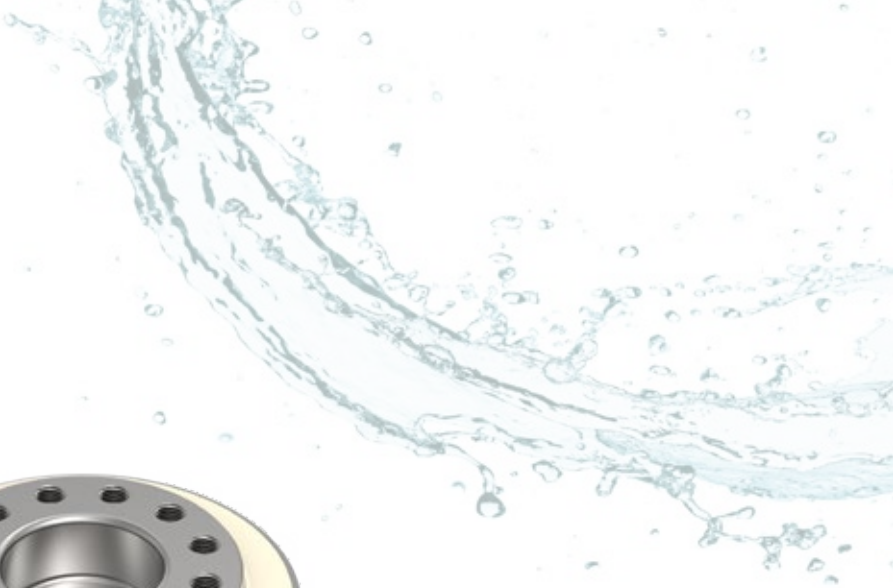

Maximum impermeability

Protection class IP69K⁽¹⁾ (max. 30 bar) with 3-fold sealing concept for maximum safety

Hygienic housing design

Housings made of smooth-rolled stainless steel 1.4404 / AISI 316L⁽¹⁾ ($R_a \leq 0.8 \mu\text{m}$)⁽¹⁾ without deadspaces and with large radii; O-ring shape according to DIN 11864⁽¹⁾

Flexibility

Connection to all conventional stainless steel motors⁽¹⁾ (options available for B14⁽¹⁾ mounting)

Safety

Food-grade lubrication (NSF, Kosher and Halal certificates)⁽¹⁾; FDA-certified materials⁽¹⁾

⁽¹⁾ See glossary for basic knowledge and definitions of terms related to hygienic design



Developed according to EHEDG guidelines

As a member of EHEDG⁽¹⁾ (European Hygienic Engineering & Design Group), we are pioneers in this field and develop our products in accordance with these strict guidelines. This means that the machines of our customers can always meet the highest demands with maximum efficiency.



Optional mounting kit

We have developed special mounting kits for our Hygienic Design⁽¹⁾ gearboxes of the HDP+ series. They guarantee hygienic connection to the application with the highest possible process reliability. For details, see page 39.

HDP+ 010 MA 2-stage

			2-stage					
Ratio	<i>i</i>		22	27.5	38.5	55		
Max. torque ^{a) b)}	T_{2a}	Nm	252	252	252	252		
		in.lb	2230	2230	2230	2230		
Max. acceleration torque ^{b)} (max. 1000 cycles per hour)	T_{2B}	Nm	185	185	185	185		
		in.lb	1637	1637	1637	1637		
Nominal torque (at n_N)	T_{2N}	Nm	140	137	139	147		
		in.lb	1242	1213	1230	1303		
Emergency stop torque ^{a) b)} (permitted 1000 times during the service life of the gearbox)	T_{2Not}	Nm	525	525	525	525		
		in.lb	4647	4647	4647	4647		
Permitted average input speed (at T_{2a} and 20 °C ambient temperature) ^{d)}	n_{1N}	rpm	4000	4000	4000	4000		
Max. input speed	n_{1Max}	rpm	7500	7500	7500	7500		
Mean no load running torque ^{b)} (at $n_l = 3000$ rpm and 20 °C gearbox temperature)	T_{012}	Nm	0.52	0.47	0.38	0.38		
		in.lb	4.6	4.2	3.4	3.4		
Max. backlash	j_t	arcmin	≤ 1					
Torsional rigidity ^{b)}	C_{t21}	Nm/arcmin	43	43	43	42		
		in.lb/arcmin	381	381	381	372		
Tilting rigidity	C_{2K}	Nm/arcmin	225					
		in.lb/arcmin	1991					
Max. axial force ^{c)}	F_{2AMax}	N	2795					
		lb _f	629					
Max. tilting moment	M_{2KMax}	Nm	400					
		in.lb	3540					
Efficiency at full load	η	%	94					
Service life	L_h	h	> 20000					
Weight (incl. standard adapter plate)	m	kg	7.3					
		lb _m	16.1					
Operating noise (at reference ratio and reference speed – ratio-specific values available in cymex [®])	L_{PA}	dB(A)	≤ 56					
Max. permitted housing temperature		°C	+90					
		F	194					
Ambient temperature		°C	-15 to +40					
		F	5 to 104					
Lubrication			Lubricated for life					
Direction of rotation			In- and output same direction					
Protection class ^{g)}			IP69K (max. 30 bar)					
Metal bellows coupling (recommended product type – validate sizing with cymex [®])			-					
Bore diameter of coupling on the application side		mm	-					
Mass moment of inertia (relates to the drive)	C	14	J_i	kgcm ²	0.16	0.14	0.11	0.10
				10 ⁻³ in.lb.s ²	0.14	0.12	0.10	0.9
Clamping hub diameter [mm] Optimized mass inertia version	E	19	J_i	kgcm ²	0.39	0.36	0.34	0.33
				10 ⁻³ in.lb.s ²	0.35	0.32	0.30	0.29

For a more detailed design, please use our cymex[®]
design software – www.wittenstein-cymex.com

^{a)} At max. 10 % M_{2KMax}

^{b)} Valid for standard clamping hub diameter

^{c)} Refers to center of the output shaft or flange

^{d)} Please reduce input speed at higher ambient temperatures

^{f)} Applies at standstill, for details see operating instructions

View A

View B

2-stage

up to 14⁴⁾ (C)⁵⁾
clamping hub diameter

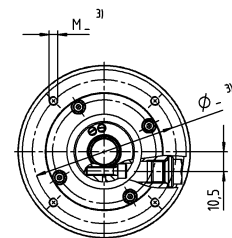
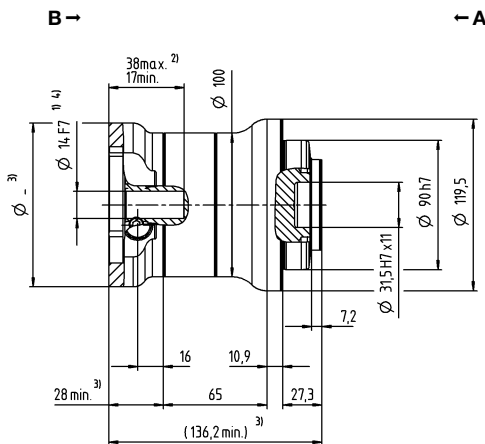
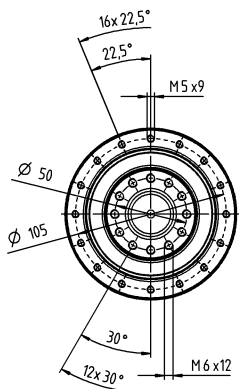

Motor shaft diameter [mm]

up to 19⁴⁾ (E)
clamping hub diameter

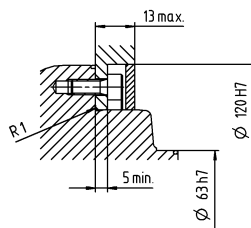
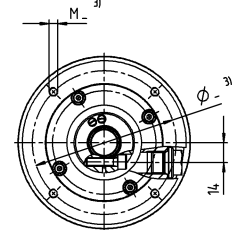
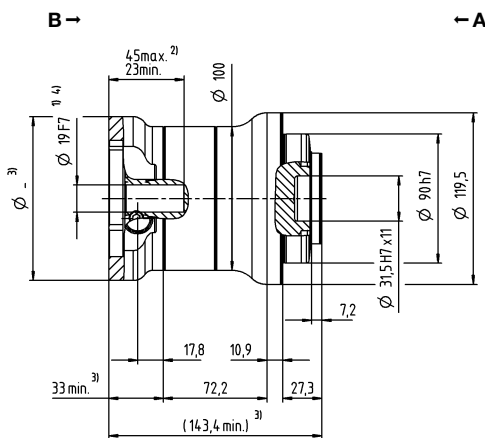
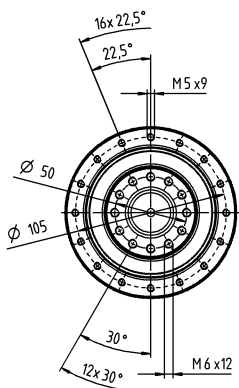

Non-tolerated dimensions are nominal dimensions

¹⁾ Check motor shaft fit

²⁾ Min./Max. permissible motor shaft length. Longer motor shafts are possible, please contact alpha.

³⁾ The dimensions depend on the motor

⁴⁾ Smaller motor shaft diameter is compensated by a bushing with a minimum wall thickness of 1 mm

⁵⁾ Standard clamping hub diameter

HDP+ 025 MA 2-stage

			2-stage					
Ratio	<i>i</i>		22	27.5	38.5	55		
Max. torque ^{a) b)}	T_{2a}	Nm	466	466	466	466		
		in.lb	4128	4128	4128	4128		
Max. acceleration torque ^{b)} (max. 1000 cycles per hour)	T_{2B}	Nm	425	425	425	425		
		in.lb	3762	3762	3762	3762		
Nominal torque (at n_N)	T_{2N}	Nm	312	314	371	413		
		in.lb	2762	2775	3286	3652		
Emergency stop torque ^{a) b)} (permitted 1000 times during the service life of the gearbox)	T_{2Not}	Nm	1200	1200	1200	1200		
		in.lb	10621	10621	10621	10621		
Permitted average input speed (at T_{2a} and 20 °C ambient temperature) ^{d)}	n_{1N}	rpm	3500	3500	3500	3500		
Max. input speed	n_{1Max}	rpm	7500	7500	7500	7500		
Mean no load running torque ^{b)} (at $n_l = 3000$ rpm and 20 °C gearbox temperature)	T_{012}	Nm	1.0	0.87	0.78	0.70		
		in.lb	9.2	7.7	6.9	6.2		
Max. backlash	j_t	arcmin	≤ 1					
Torsional rigidity ^{b)}	C_{t21}	Nm/arcmin	100	100	100	100		
		in.lb/arcmin	885	885	885	885		
Tilting rigidity	C_{2K}	Nm/arcmin	550					
		in.lb/arcmin	4868					
Max. axial force ^{c)}	F_{2AMax}	N	4800					
		lb _f	1080					
Max. tilting moment	M_{2KMax}	Nm	550					
		in.lb	4868					
Efficiency at full load	η	%	94					
Service life	L_h	h	> 20000					
Weight (incl. standard adapter plate)	m	kg	11.1					
		lb _m	24.5					
Operating noise (at reference ratio and reference speed – ratio-specific values available in cymex [®])	L_{PA}	dB(A)	≤ 58					
Max. permitted housing temperature		°C	+90					
		F	194					
Ambient temperature		°C	-15 to +40					
		F	5 to 104					
Lubrication			Lubricated for life					
Direction of rotation			In- and output same direction					
Protection class ^{g)}			IP69K (max. 30 bar)					
Metal bellows coupling (recommended product type – validate sizing with cymex [®])			-					
Bore diameter of coupling on the application side		mm	-					
Mass moment of inertia (relates to the drive)	E	19	J_i	kgcm ²	0.75	0.57	0.47	0.42
				10 ⁻³ in.lb.s ²	0.67	0.52	0.42	0.37
Clamping hub diameter [mm] Optimized mass inertia version	G	24	J_i	kgcm ²	1.77	1.59	1.49	1.44
				10 ⁻³ in.lb.s ²	1.57	1.41	1.32	1.28

For a more detailed design, please use our cymex[®]
design software – www.wittenstein-cymex.com

^{a)} At max. 10 % M_{2KMax}

^{b)} Valid for standard clamping hub diameter

^{c)} Refers to center of the output shaft or flange

^{d)} Please reduce input speed at higher ambient temperatures

^{f)} Applies at standstill, for details see operating instructions

View A

View B

2-stage

up to 19⁴⁾ (E)⁵⁾
clamping hub
diameter

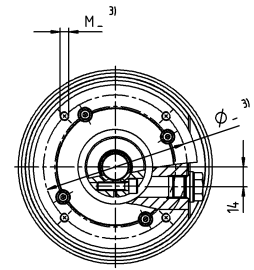
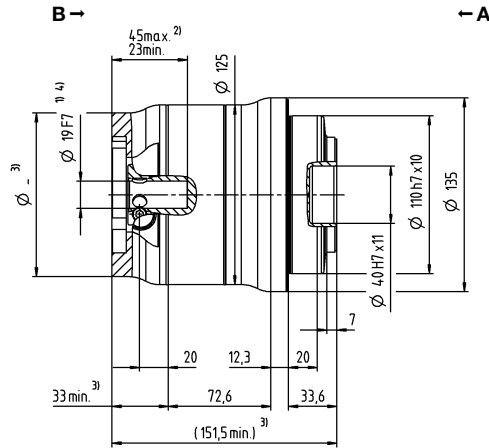
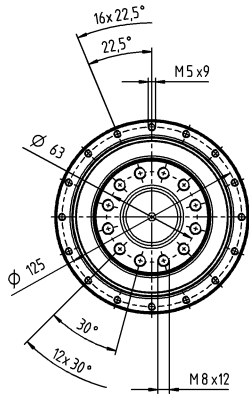

Motor shaft diameter [mm]

up to 24⁴⁾ (G)
clamping hub
diameter

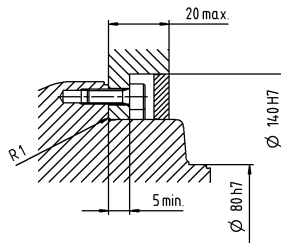
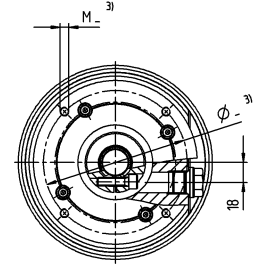
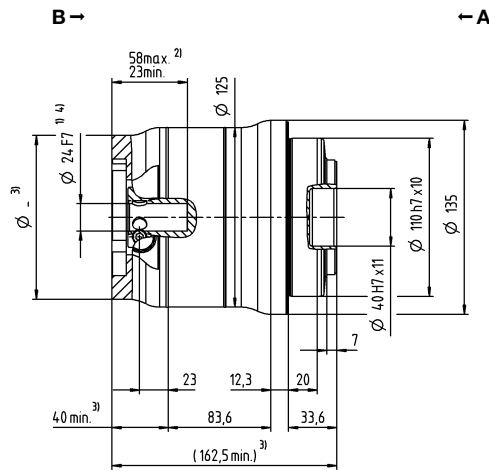
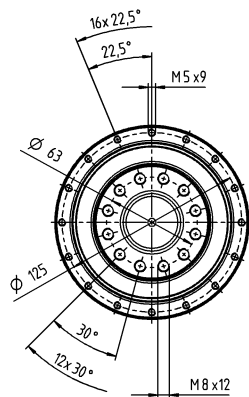

Non-tolerated dimensions are nominal dimensions

¹⁾ Check motor shaft fit

²⁾ Min./Max. permissible motor shaft length. Longer motor shafts are possible, please contact alpha.

³⁾ The dimensions depend on the motor

⁴⁾ Smaller motor shaft diameter is compensated by a bushing with a minimum wall thickness of 1 mm

⁵⁾ Standard clamping hub diameter

axenia value – absolutely clean and compact

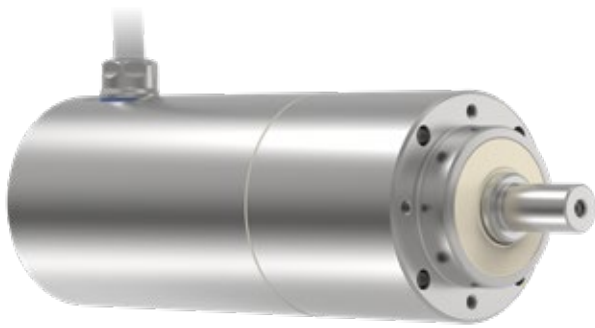

The axenia value servo actuator complements the existing Hygienic Design[®] portfolio with HDV and HDP+ gearboxes. The axenia value servo actuator stands for a safe and hygienic servo actuator design with verified protection class and material resistance. The performance data is reliable, without subsequent derating of the motor.

Product highlights

- Power density:**
 Thanks to the compact design of the servo actuator, the performance, measured by volume or installation length, is increased by approx. 50%.
- Reliability:**
 The specified performance data of the actuator is measured and reliable. When using individual components, derating of 30 to 50 % is usually required.
- Durability:**
 The servo actuator is tested as a unit with regard to protection class[®]. The critical interface between motor and gearbox at different manufacturers is eliminated. The material of the housings and the material of the seals are characterized by very high resistance.
- Connectivity:**
 Wide selection of analog and digital motor encoders, in conjunction with single-cable connection.
- Certification:**
 Comprehensive market access is possible through UL approval (in preparation), DFC certification and development according to EHEDG specifications[®].

The axenia value compared to the industry standard

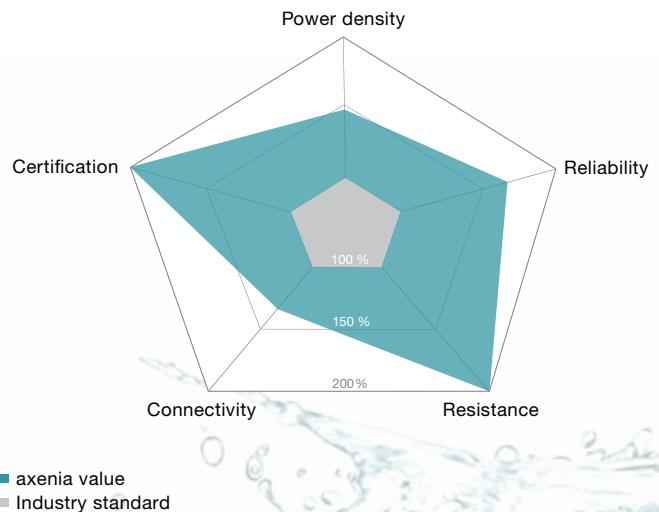

Compact machine design

The slicers of the series Formax[®] SX330[™] and SX380[™] cut a wide range of products with low changeover time. By using axenia value, high productivity is achieved with a small footprint.

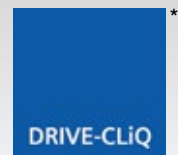

Connectivity

Together with the digital encoder systems, axenia value offers the greatest connectivity on the market, enabling connection to almost all common servo controllers.

* In preparation

TECHNICAL DETAILS AND CUSTOMER BENEFITS

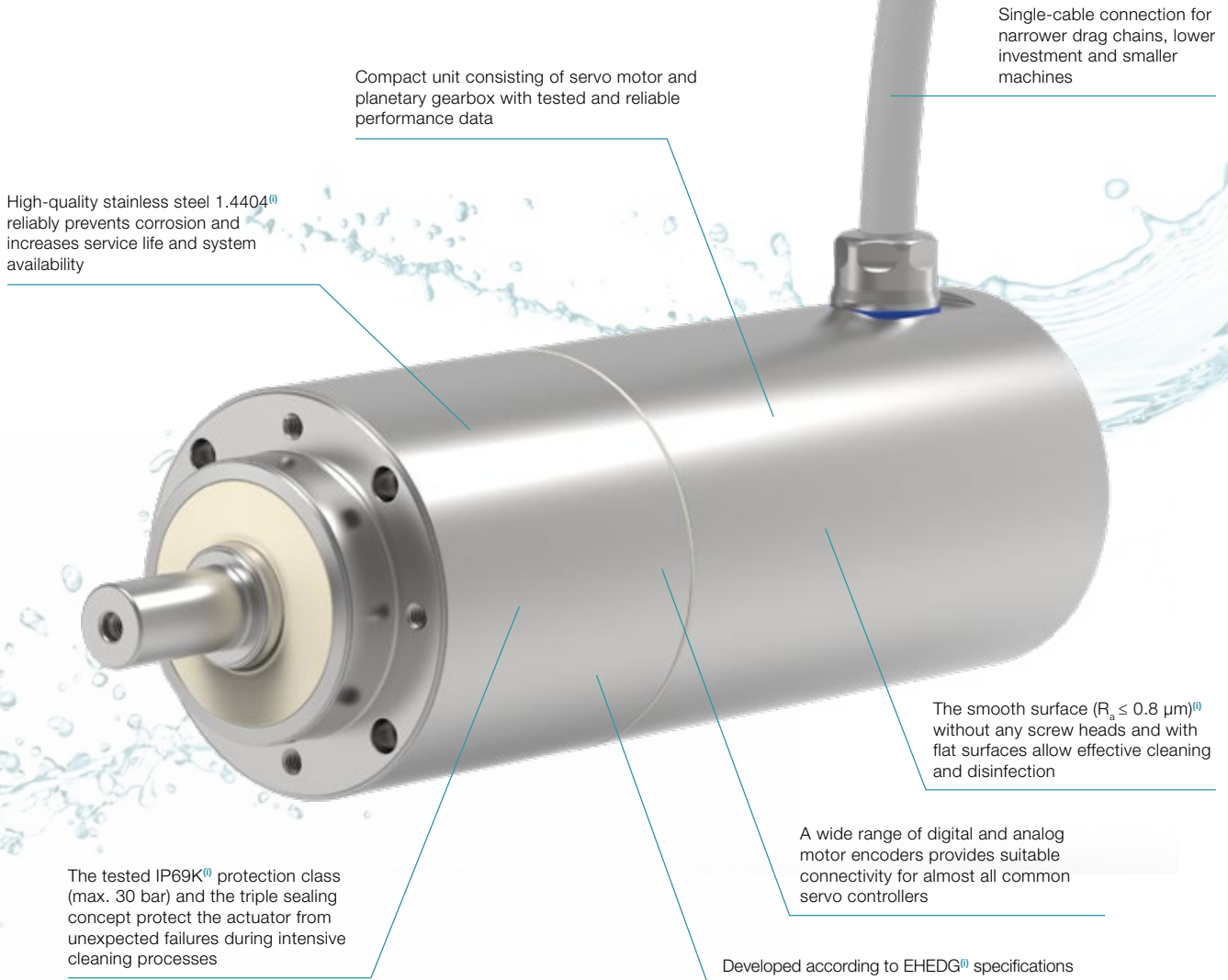

High-quality stainless steel 1.4404[®] reliably prevents corrosion and increases service life and system availability

Compact unit consisting of servo motor and planetary gearbox with tested and reliable performance data

Single-cable connection for narrower drag chains, lower investment and smaller machines

The smooth surface ($R_a \leq 0.8 \mu\text{m}$)[®] without any screw heads and with flat surfaces allow effective cleaning and disinfection

A wide range of digital and analog motor encoders provides suitable connectivity for almost all common servo controllers

The tested IP69K[®] protection class (max. 30 bar) and the triple sealing concept protect the actuator from unexpected failures during intensive cleaning processes

Developed according to EHEDG[®] specifications

[®] See glossary for basic knowledge and definitions of terms related to hygienic design

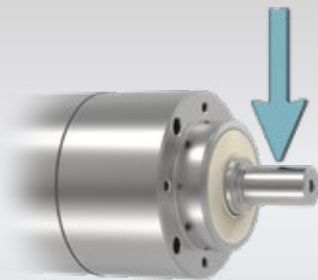

HIGH FORCES (standard for axenia value)

With its reinforced output bearing, the axenia value servo actuator offers up to 6 times higher tilting moment as well as increased axial and lateral force.



Optional mounting kit

We have developed special mounting kits for axenia value. They guarantee hygienic connection to the application with the highest possible process reliability. For details, see page 39.

AVF 1 1/2-stage

			1-stage		2-stage	
Ratio	i		10	16	20	25
Operating voltage	U_D	V DC	560	560		
Max. acceleration torque ^{a)} (max. 1000 cycles per hour)	T_{2B}	Nm	20.2	31.7	32.0	32.0
		in.lb	179	281	283	283
Static output torque (Value for unit without brake)	T_{20}	Nm	5.37	8.5	10.6	13.2
		in.lb	48	75	94	117
Brake holding torque ^{b)} (at 120°C)	T_{2Br}	Nm	7.80	12.5	15.6	19.5
		in.lb	69	111	138	173
Max. speed at output	n_{2max}	rpm	600	375	300	240
Speed limit for T_{2B}	n_{2B}	rpm	600	375	300	240
Max. motor acceleration torque	T_{1max}	Nm	2.1	2.1	2.1	2.1
		in.lb	19	19	19	19
Max. motor acceleration current	I_{MaxDyn}	A_{eff}	3.5	3.5	3.5	3.5
Static motor current (Value for unit without brake)	I_0	A_{eff}	0.94	0.92	0.92	0.92
Max. backlash	j_t	arcmin	≤ 10	≤ 15		
Torsional rigidity (Gearbox)	C_{t21}	Nm/arcmin	2.0	2.3	2.3	2.3
		in.lb/arcmin	18	20	20	20
Max. axial force ^{c)}	F_{2AMax}	N	1000	1000		
		lb _f	225	225		
Max. lateral force ^{c)}	F_{2QMax}	N	1600	1600		
		lb _f	360	360		
Max. tilting moment ^{d)}	M_{2KMMax}	Nm	105	105		
		in.lb	929	929		
Service life	L_n	h	> 20000	> 20000		
Weight (with brake)	m	kg	5.6	6.2		
		lb _m	12	14		
Ambient temperature		°C	-18 to +40	-18 to +40		
		°F	0 to +104	0 to +104		
Lubrication			Lubricated for life			
Insulating material class			F			
Protection class ^{e)}			IP69K (max. 30 bar)			
Mass moment of inertia (with brake, relates to the drive)	J_1	kgcm ²	0.22	0.24	0.23	0.23
		10 ⁻³ in.lb.s ²	0.19	0.21	0.20	0.20

For a more detailed design, please use our cymex® design software – www.wittenstein-cymex.com

Technical data and characteristics for 30K and 50K (surface temperature above ambient temperature) are available on request.

^{a)} Valid for: Smooth shaft

^{b)} Observe project planning notes in operating manual

^{c)} Refers to center of the output shaft or flange

^{d)} Refers to the inner radial bearing of the output stage

^{e)} Applies at standstill, for details see operating instructions

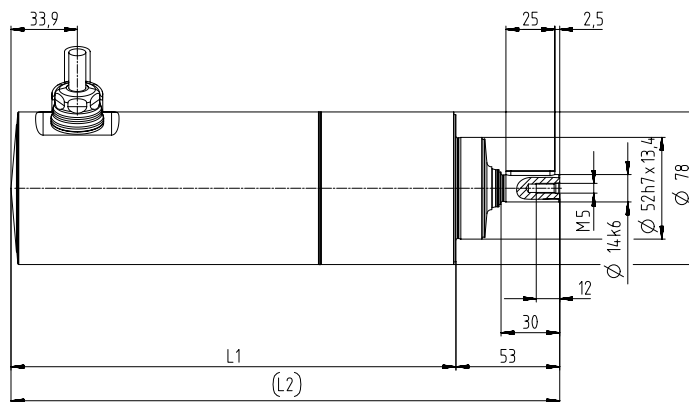
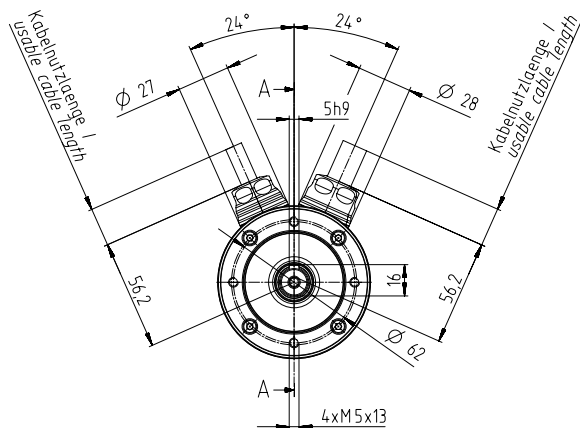

Ratio	Length L1 in mm	Length L2 in mm
i = 10	207.4	260.4
i = 16 – 25	227.4	280.4

Other drive variants

Smooth shaft

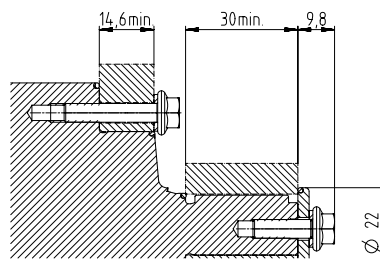
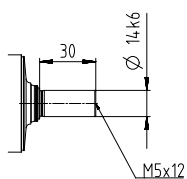

Assembly accessories:
Mounting kit consisting of stainless steel screws,
discs, seals and O-rings.

Non-tolerated dimensions are nominal dimensions

AVF 2 1/2-stage

			1-stage	2-stage		
Ratio	i		10	16	20	25
Operating voltage	U_D	VDC	560	560		
Max. acceleration torque ^{a)} (max. 1000 cycles per hour)	T_{2B}	Nm	52.2	80.0	80.0	80.0
		in.lb	462	708	708	708
Static output torque (Value for unit without brake)	T_{20}	Nm	13.00	21.6	27.0	33.8
		in.lb	115	191	239	299
Brake holding torque ^{b)} (at 120°C)	T_{2Br}	Nm	7.80	12.5	15.6	19.5
		in.lb	69	111	138	173
Max. speed at output	n_{2max}	rpm	600	375	300	240
Speed limit for T_{2B}	n_{2B}	rpm	600	375	300	240
Max. motor acceleration torque	T_{1max}	Nm	5.4	5.4	5.4	5.4
		in.lb	48	48	48	48
Max. motor acceleration current	I_{MaxDyn}	A_{eff}	7.3	7.3	7.3	7.3
Static motor current (Value for unit without brake)	I_0	A_{eff}	1.86	1.94	1.94	1.94
Max. backlash	j_t	arcmin	≤ 10	≤ 15		
Torsional rigidity (Gearbox)	C_{t21}	Nm/arcmin	5.5	7.5	7.5	7.5
		in.lb/arcmin	49	66	66	66
Max. axial force ^{c)}	F_{2AMax}	N	1500	1500		
		lb _f	338	338		
Max. lateral force ^{c)}	F_{2QMax}	N	2500	2500		
		lb _f	563	563		
Max. tilting moment ^{d)}	M_{2KMMax}	Nm	185	185		
		in.lb	1637	1637		
Service life	L_n	h	> 20000	> 20000		
Weight (with brake)	m	kg	9.9	11.1		
		lb _m	22	25		
Ambient temperature		°C	-18 to +40	-18 to +40		
		°F	0 to +104	0 to +104		
Lubrication			Lubricated for life			
Insulating material class			F			
Protection class ^{e)}			IP69K (max. 30 bar)			
Mass moment of inertia (with brake, relates to the drive)	J_1	kgcm ²	0.51	0.66	0.57	0.59
		10 ⁻³ in.lb.s ²	0.45	0.58	0.5	0.52

For a more detailed design, please use our cymex® design software – www.wittenstein-cymex.com

Technical data and characteristics for 30K and 50K (surface temperature above ambient temperature) are available on request.

^{a)} Valid for: Smooth shaft

^{b)} Observe project planning notes in operating manual

^{c)} Refers to center of the output shaft or flange

^{d)} Refers to the inner radial bearing of the output stage

^{e)} Applies at standstill, for details see operating instructions

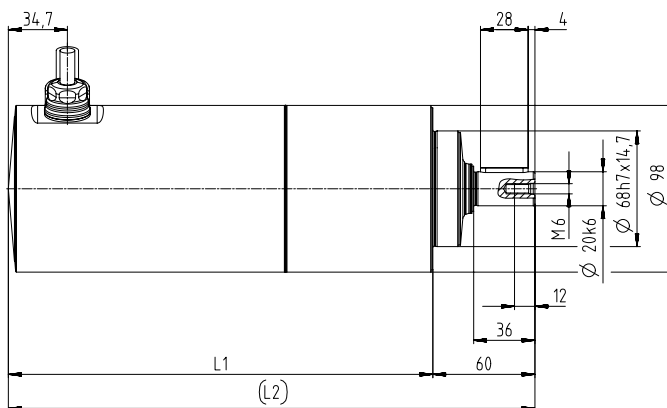
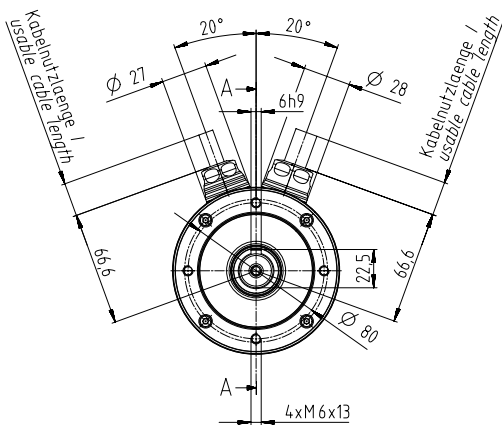

Ratio	Length L1 in mm	Length L2 in mm
i = 10	223	283
i = 16 – 25	249.5	309.5

Other drive variants

Smooth shaft

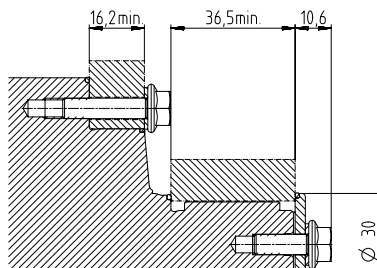
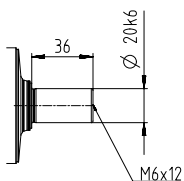

Assembly accessories:
Mounting kit consisting of stainless steel screws, discs, seals and O-rings.

Non-tolerated dimensions are nominal dimensions

AVF 3 1/2-stage

			1-stage	2-stage		
Ratio	i		10	16	20	25
Operating voltage	U_D	VDC	560	560		
Max. acceleration torque ^{a)} (max. 1000 cycles per hour)	T_{2B}	Nm	125	196	200	200
		in.lb	1106	1735	1770	1770
Static output torque (Value for unit without brake)	T_{20}	Nm	31.1	49.3	61.6	77.0
		in.lb	275	436	545	682
Brake holding torque ^{b)} (at 120°C)	T_{2Br}	Nm	28.6	45.8	57.2	71.5
		in.lb	253	405	506	633
Max. speed at output	n_{2max}	rpm	480	300	240	192
Speed limit for T_{2B}	n_{2B}	rpm	480	300	240	192
Max. motor acceleration torque	T_{1max}	Nm	13.0	13.0	13.0	13.0
		in.lb	115	115	115	115
Max. motor acceleration current	I_{MaxDyn}	A_{eff}	19.0	19.0	19.0	19.0
Static motor current (Value for unit without brake)	I_0	A_{eff}	4.12	4.05	4.05	4.05
Max. backlash	j_t	arcmin	≤ 10	≤ 15		
Torsional rigidity (Gearbox)	C_{t21}	Nm/arcmin	22.0	24	24	24
		in.lb/arcmin	195	212	212	212
Max. axial force ^{c)}	F_{2AMax}	N	3000	3000		
		lb _f	675	675		
Max. lateral force ^{c)}	F_{2QMax}	N	4250	4250		
		lb _f	956	956		
Max. tilting moment ^{d)}	M_{2KMax}	Nm	407	407		
		in.lb	3602	3602		
Service life	L_n	h	> 20000	> 20000		
Weight (with brake)	m	kg	21.3	24.4		
		lb _m	47	54		
Ambient temperature		°C	-18 to +40	-18 to +40		
		°F	0 to +104	0 to +104		
Lubrication			Lubricated for life			
Insulating material class			F			
Protection class ^{e)}			IP69K (max. 30 bar)			
Mass moment of inertia (with brake, relates to the drive)	J_1	kgcm ²	2.67	3.08	2.9	2.97
		10 ⁻³ in.lb.s ²	2.4	2.7	2.6	2.6

For a more detailed design, please use our cymex® design software – www.wittenstein-cymex.com

Technical data and characteristics for 30K and 50K (surface temperature above ambient temperature) are available on request.

^{a)} Valid for: Smooth shaft

^{b)} Observe project planning notes in operating manual

^{c)} Refers to center of the output shaft or flange

^{d)} Refers to the inner radial bearing of the output stage

^{e)} Applies at standstill, for details see operating instructions

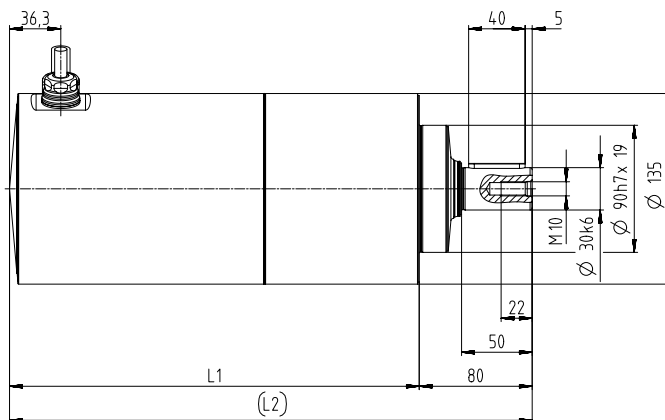
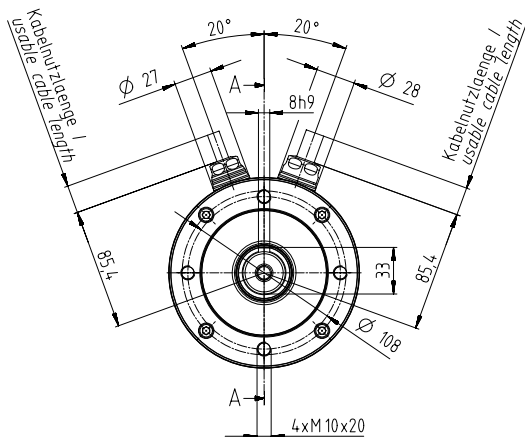

Ratio	Length L1 in mm	Length L2 in mm
i = 10	257.6	337.6
i = 16 – 25	290.1	370.1

Other drive variants

Smooth shaft

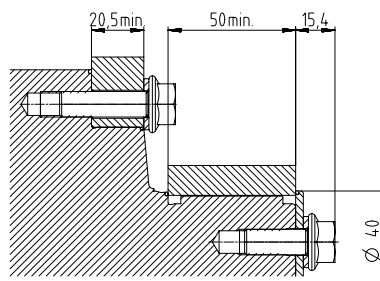
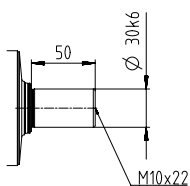

Assembly accessories:
Mounting kit consisting of stainless steel screws, discs, seals and O-rings.

Non-tolerated dimensions are nominal dimensions

Ordering code – HDV and HDP+

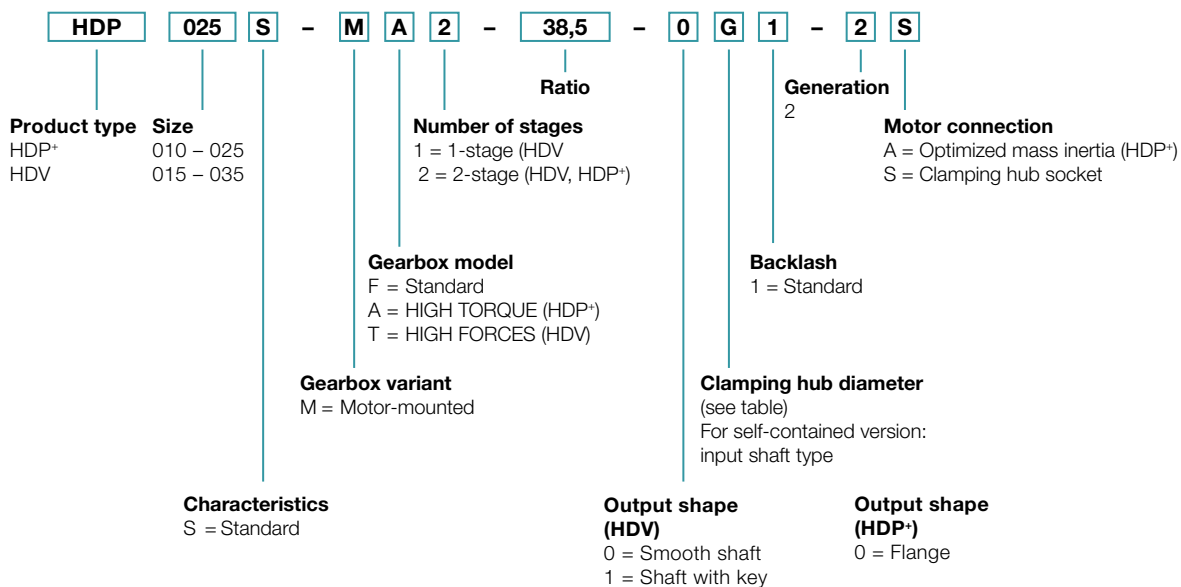

Mounting positions and clamping hub diameters

B5
Horizontal

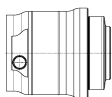

V1
Output vertical downwards

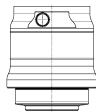

V3
Output vertical upwards

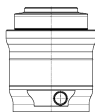

S
Can be tilted $\pm 90^\circ$ from a horizontal position

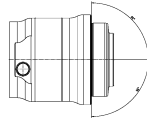

Clamping hub diameter
(see technical data sheet for possible diameters)

Code letter	mm
B	11
C	14
E	19
G	24
H	28

Intermediate sizes possible using bushings with a minimum thickness of 1 mm.

For information only – not relevant for order!

Exceptions:

- The HDP+ is designed for mounting position B5 as standard!
- Please contact WITTENSTEIN alpha for deviating mounting positions.

Ordering code – axenia value

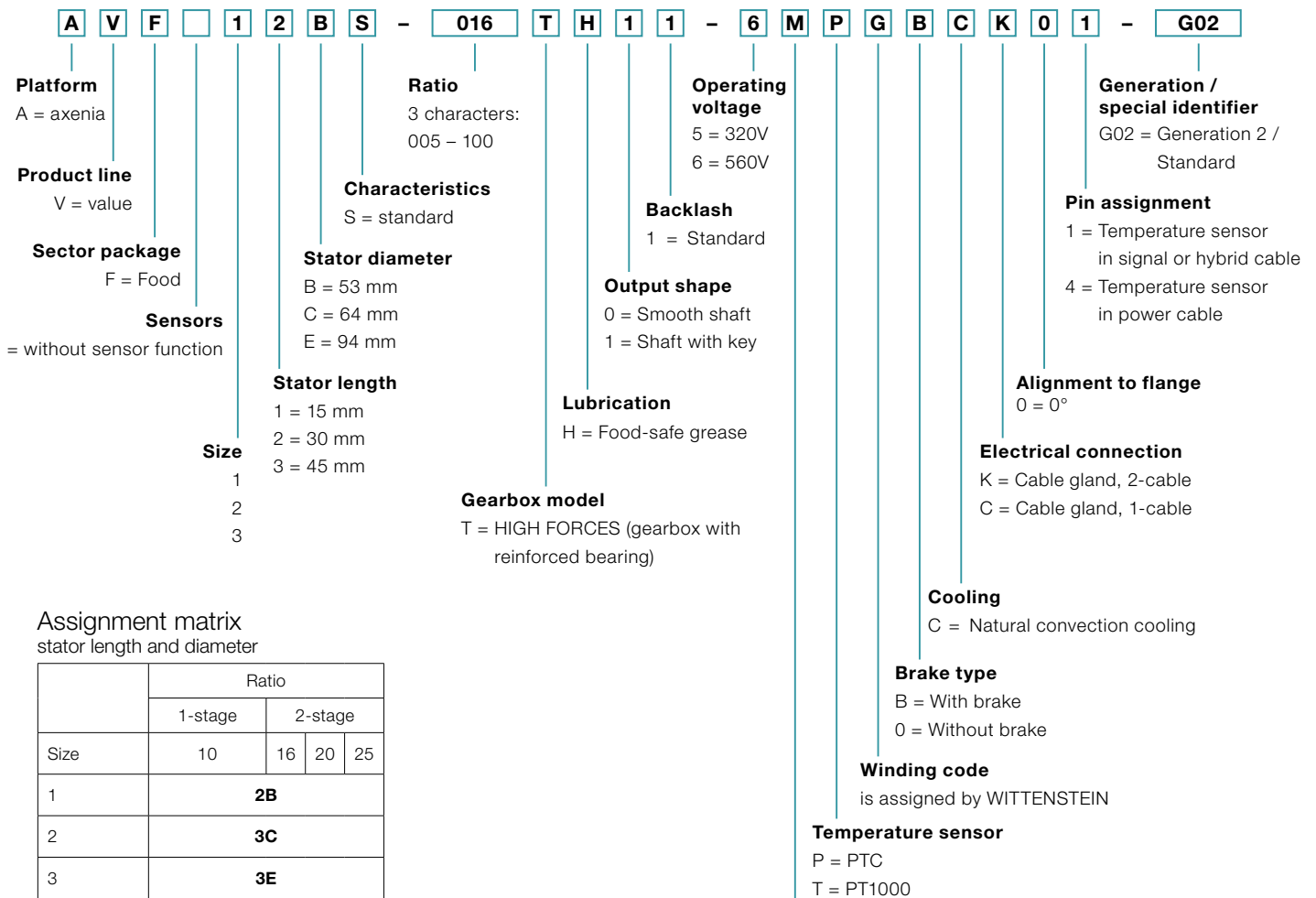

Assignment matrix
stator length and diameter

	Ratio			
	1-stage	2-stage		
Size	10	16	20	25
1	2B			
2	3C			
3	3E			

Encoder

- R = Resolver, 2-pin
- S = EnDat 2.1 absolute, singleturn
- M = EnDat 2.1 absolute, multiturn
- F = EnDat 2.2 absolute, singleturn
- W = EnDat 2.2 absolute, multiturn
- N = Hiperface absolute, singleturn
- K = Hiperface absolute, multiturn
- G = Hiperface DSL absolute, singleturn
- H = Hiperface DSL absolute, multiturn
- L = DRIVE-CLiQ absolute, singleturn (on request)
- D = DRIVE-CLiQ absolute, multiturn (on request)
- E = Rockwell Hiperface absolute, singleturn
- V = Rockwell Hiperface absolute, multiturn
- J = Rockwell Hiperface DSL absolute, singleturn
- P = Rockwell Hiperface DSL absolute, multiturn

Ordering code – axenia value cables

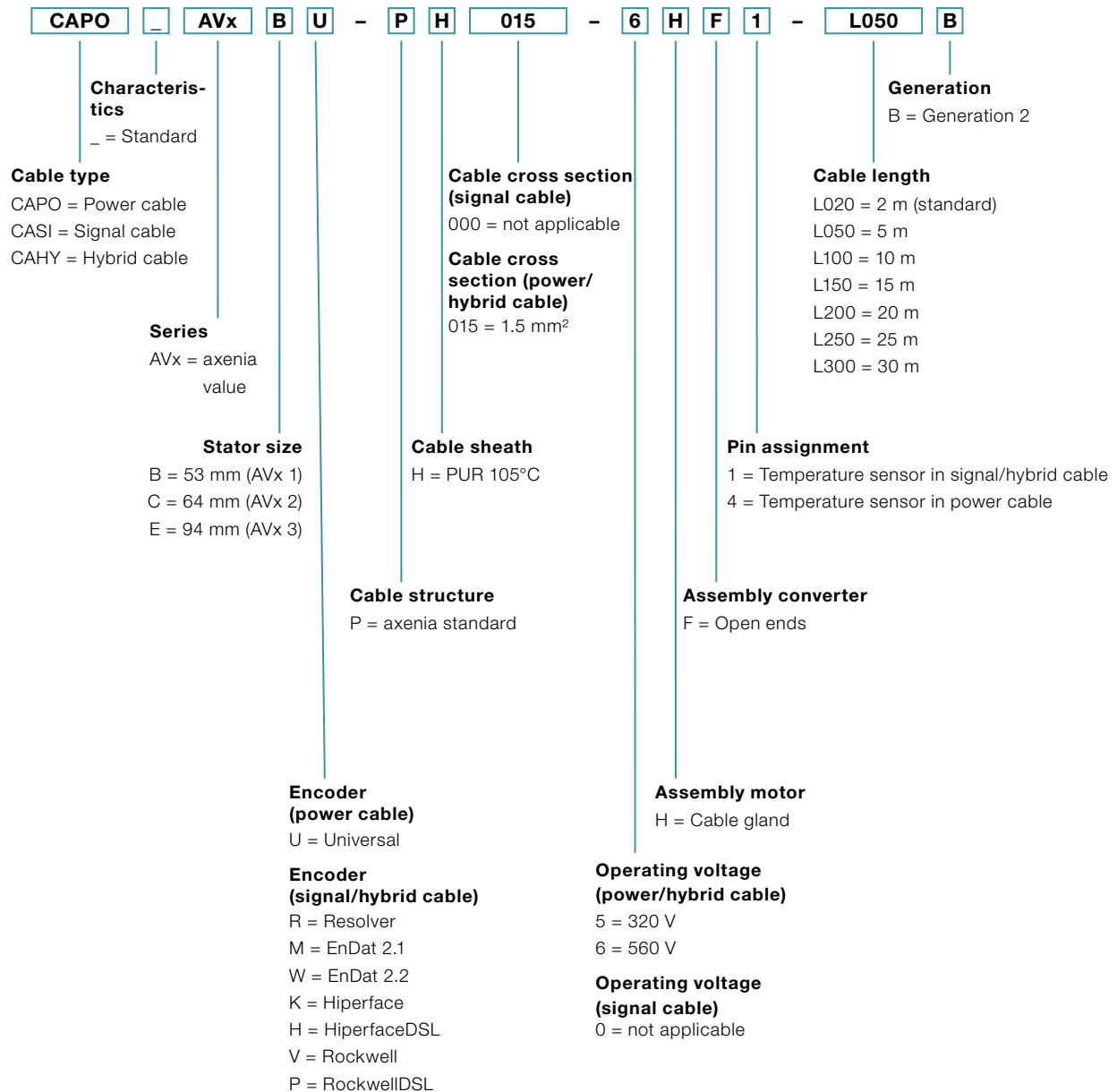

Mounting kit – Hygienic mounting

Hygienically safe mounting

Our Hygienic Design[®] products have been designed for applications that require maximum cleanability and leak protection. To meet these requirements in a comprehensive approach all the way to the connection of the gearbox, the gearbox must be mounted to the product in a tailor-made and hygienically safe manner. Therefore we have developed special mounting kits to ensure a hygienic connection with maximum process reliability. The sealing parts and screws included in the mounting kits prevent hygienic weak spots and seal cavities on the application side.

HDV and axenia value:

The mounting kit for our HDV and axenia value includes:

- O-rings to seal the direct contact surfaces between gearbox and machine
- A suitable stainless steel[®] screw set with screw head seals for assembly to the machine
- A disc to seal the centering in the output shaft

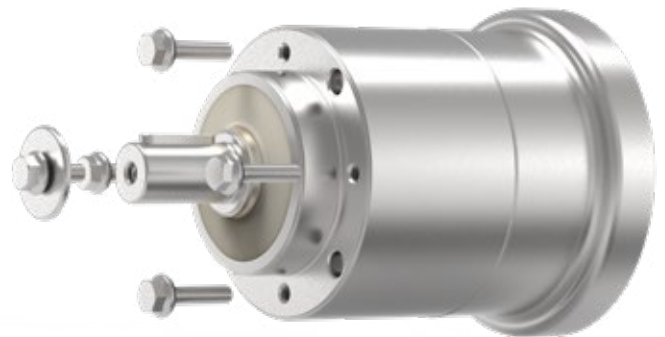

HDP+:

The hygienic mounting kit for our HDP+ contains:

- O-rings to seal the direct contact surfaces between gearbox and machine
- a sealing disc for the final sealing of the flange connection

Advantages for you:

- Take advantage of the opportunities to save storage capacities by packaging of the mounting material
- Benefit from a comprehensive solution for maximum process reliability

If you have any questions, please don't hesitate to contact your sales representative or WITTENSTEIN alpha.

[®] See glossary for basic knowledge and definitions of terms related to hygienic design

cyber[®] dynamic line – Servo motors and actuators in Hygienic Design

Hygienic and sterile

The brushless small servo motors of the cyber[®] dynamic line in Hygienic Design are three-phase, permanently excited synchronous motors. They have an outer diameter of 40 mm, are designed for power ranges up to 335 W and are equipped with an absolute encoder with BISS C interface (single or multi-turn). Thanks to their high dynamic factor, the motors achieve peak values in acceleration, cycle rates and machine throughput.

The products have been consistently designed for the environment of hygienic production and packaging in accordance with the EHEDG specifications (European Hygienic Engineering & Design Group). The direct integration of the drive technology into the process opens up new design freedom. Optionally, this variant can be extended with a planetary gearbox and with a holding brake. This enables torques of up to 8 Nm to be achieved with an outer diameter of 40 mm.

Product highlights

- Suited for hygienic and sterile production
- Direct contact with food allowed
- Fast, efficient and reliable cleaning
- Resistant to chemical cleaning materials and disinfectants
- Optimal sealing properties (IP69K)
- Maximum resistance to corrosion
- New design freedom because the drive is integrated directly in the process

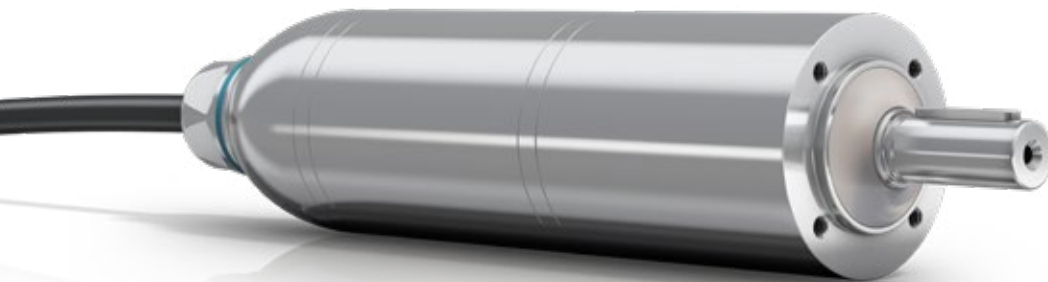

cyber[®] dynamic actuator R in Hygienic Design

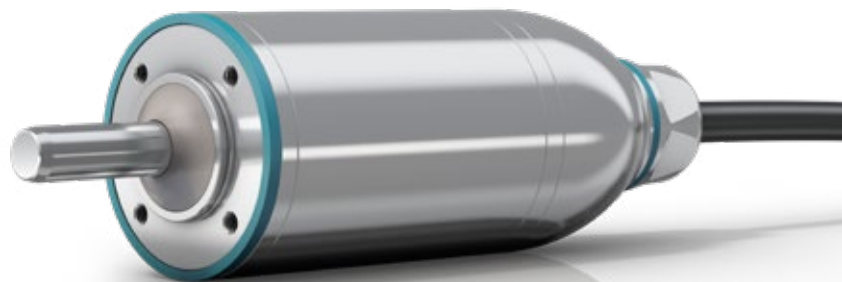



cyber[®] dynamic motor in Hygienic Design

Typical areas of applications and industry solutions

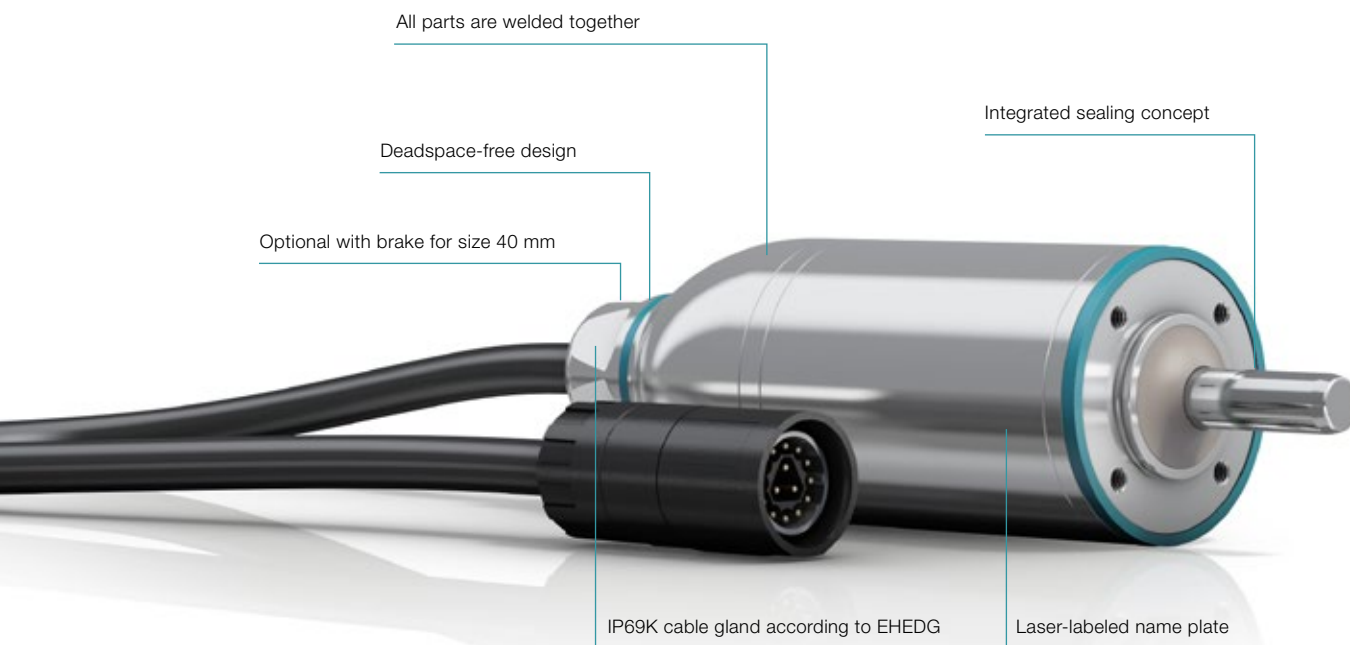
- Dosing
- Packaging
- Pharma
- Food & beverages
- Assembly & handling



Designs

	Hygienic Design	Inox Design	Standard Design
			
Design	Hygienic (according to EHEDG guidelines)	Standard with PG-cable gland	Standard with plastic cap
Size (Outer diameter in mm)	40	17 / 22 / 32 / 40	17 / 22 / 32 / 40
Protection class Shaft Cable outlet	IP67 IP69K (max. 30 bar)	IP20 IP66/67	IP20 IP54
Housing material	Corrosion-resistant stainless steel (V2A)	Corrosion-resistant stainless steel (V2A)	Corrosion-resistant stainless steel (V2A) and plastic (PA6)
Shaft material	Corrosion-resistant stainless steel (V2A)	Steel	Steel
Lubrication	Lubricated for life Food grade (NSF/H1)	Lubricated for life Standard grease	Lubricated for life Standard grease
Certification	CE	CE, UL (cRUus) for size 32 / 40	CE
Gearbox	optional	optional	optional
Screw drive	no	optional	optional

Basic Line gearbox overview



Product type		CP	CPS	CPK	CPSK	CVH	CVS
Version		MF	MF	MF	MF	MF / MT	MF / MT
Ratio ^{c)}	min. $i =$	3	3	3	3	7	7
	max. $i =$	100	100	100	100	40	40
Max. torsional backlash [arcmin] ^{c)}	Standard	≤ 12	≤ 12	≤ 15	≤ 15	≤ 15	≤ 15
	Reduced	–	–	–	–	–	–
Output type							
Smooth shaft		x	x	x	x	–	x
Shaft with key ^{d)}		x	x	x	x	–	x
Splined shaft (DIN 5480)		–	–	–	–	–	–
Blind hollow shaft		–	–	–	–	–	–
Hollow shaft interface		–	–	–	–	x	–
Keyed hollow shaft		–	–	–	–	x	–
Flanged hollow shaft		–	–	–	–	–	–
Flange		–	–	–	–	–	–
System output		–	–	–	–	–	–
Output on both sides		–	–	–	–	x	x
Input type							
Motor-mounted		x	x	x	x	x	x
Self-contained version ^{b)}		–	–	–	–	–	–
Characteristic							
Flange with slotted holes		–	–	–	–	–	–
ATEX ^{a)}		–	–	–	–	–	–
Food-grade lubrication ^{a) b)}		x	x	x	x	x	x
Corrosion resistant ^{a) b)}		–	–	–	–	–	–
Optimized mass inertia ^{a)}		–	–	–	–	–	–
System solutions							
Linear system (rack/pinion)		–	–	–	–	–	–
Servo actuator		–	–	–	–	–	–
Accessories (please refer to the product pages for further options)							
Coupling		x	x	x	x	–	x
Shrink disc		–	–	–	–	x	–

^{a)} Power reduction: technical data available on request

^{b)} Please contact WITTENSTEIN alpha

^{c)} In relation to reference sizes

^{d)} Power reduction: Please use our sizing software cymex[®] for a detailed sizing – www.wittenstein-cymex.com

Value Line gearbox overview



Product type		NP	NPL	NPS	NPT	NPR	NTP	NPK	NPLK	NPSK	NPTK	NPRK	NVH	NVS	HDV
Version		MF/MA	MF/MA	MF/MA	MF/MA	MF/MA	MQ	MF	MF	MF	MF	MF	MF	MF	MF/MT
Ratio ^{d)}	min. $i =$	3	3	3	3	3	4	3	3	3	3	3	4	4	4
	max. $i =$	100	100	100	100	100	100	100	100	100	100	100	400	400	400
Max. torsional backlash [arcmin] ^{d)}	Standard	≤ 8	≤ 8	≤ 8	≤ 8	≤ 8	≤ 5	≤ 11	≤ 11	≤ 11	≤ 11	≤ 11	≤ 6	≤ 6	≤ 10
	Reduced	-	-	-	-	-	-	-	-	-	-	-	-	-	-
Output type															
Smooth shaft		x	x	x	-	x	-	x	x	x	-	x	-	x	x
Shaft with key ^{d)}		x	x	x	-	x	-	x	x	x	-	x	-	x	x
Splined shaft (DIN 5480)		-	x	x	-	x	-	-	x	x	-	x	-	-	-
Blind hollow shaft		-	-	-	-	-	-	-	-	-	-	-	-	-	-
Hollow shaft interface		-	-	-	-	-	-	-	-	-	-	-	x	-	-
Keyed hollow shaft		-	-	-	-	-	-	-	-	-	-	-	x	-	-
Flanged hollow shaft		-	-	-	-	-	-	-	-	-	-	-	-	-	-
Flange		-	-	-	x	-	x	-	-	-	x	-	-	-	-
System output		-	-	-	-	-	-	-	-	-	-	-	-	-	-
Output on both sides		-	-	-	-	-	-	-	-	-	-	-	x	x	-
Input type															
Motor-mounted		x	x	x	x	x	x	x	x	x	x	x	x	x	x
Self-contained version ^{b)}		-	-	-	-	-	-	-	-	-	-	-	-	-	-
Characteristic															
Flange with slotted holes		-	-	-	-	x	-	-	-	-	-	x	-	-	-
ATEX ^{a)}		-	-	-	-	-	-	-	-	-	-	-	-	-	-
Food-grade lubrication ^{a) b)}		x	x	x	x	x	x	x	x	x	x	x	x	x	x
Corrosion resistant ^{a) b)}		-	-	-	-	-	-	-	-	-	-	-	x	x	x
Optimized mass inertia ^{a)}		-	-	-	-	-	-	-	-	-	-	-	-	-	-
System solutions															
Linear system (rack/pinion)		x	x	x	-	x	-	x	x	x	-	x	-	x	-
Servo actuator		-	-	-	-	-	-	-	-	-	-	-	-	-	x
Accessories (please refer to the product pages for further options)															
Coupling		x	x	x	x	x	x	x	x	x	-	x	-	x	-
Shrink disc		-	-	-	-	-	-	-	-	-	-	-	x	-	-

^{a)} Power reduction: technical data available on request

^{b)} Please contact WITTENSTEIN alpha

^{c)} In relation to reference sizes

^{d)} Power reduction: Please use our sizing software cymex[®] for a detailed sizing – www.wittenstein-cymex.com

Advanced Line gearbox overview



Product type		SP+	SP+ HIGH SPEED	SP+ HIGH SPEED friction optimized	TP+	TP+ HIGH TORQUE	HG+	SK+	SPK+
Version		MF	MC	MC-L	MF	MA	MF	MF	MF
Ratio ^{c)}	min. i =	3	3	3	4	22	3	3	12
	max. i =	100	100	10	100	302.5	100	100	10000
Max. torsional backlash [arcmin] ^{c)}	Standard	≤ 3	≤ 4	≤ 4	≤ 3	≤ 1	≤ 4	≤ 4	≤ 4
	Reduced	≤ 1	≤ 2	≤ 2	≤ 1	–	–	–	≤ 2
Output type									
Smooth shaft		x	x	x	–	–	–	x	x
Shaft with key ^{d)}		x	x	x	–	–	–	x	x
Splined shaft (DIN 5480)		x	x	x	–	–	–	x	x
Blind hollow shaft		x	x	x	–	–	–	–	x
Hollow shaft interface		–	–	–	–	–	x	–	–
Keyed hollow shaft		–	–	–	–	–	–	–	–
Flanged hollow shaft		–	–	–	–	–	–	–	–
Flange		–	–	–	x	x	–	–	–
System output		–	–	–	x	x	–	–	–
Output on both sides		–	–	–	–	–	x	x	x
Input type									
Motor-mounted		x	x	x	x	x	x	x	x
Self-contained version ^{b)}		x	–	–	x	–	–	–	–
Characteristic									
Flange with slotted holes		x	–	–	–	–	–	–	–
ATEX ^{a)}		x	x	–	–	–	x	x	–
Food-grade lubrication ^{a) b)}		x	x	x	x	x	x	x	x
Corrosion resistant ^{a) b)}		x	x	x	x	x	x	x	x
Optimized mass inertia ^{a)}		x	x	x	x	x	–	–	–
System solutions									
Linear system (rack/pinion)		x	x	–	x	x	–	x	x
Servo actuator		x	–	–	x	x	–	–	–
Accessories (please refer to the product pages for further options)									
Coupling		x	x	x	x	x	–	x	x
Shrink disc		x	x	x	–	–	x	–	x

^{a)} Power reduction: technical data available on request

^{b)} Please contact WITTENSTEIN alpha

^{c)} In relation to reference sizes

^{d)} Power reduction: Please use our sizing software cymex® for a detailed sizing – www.wittenstein-cymex.com



TK+	TPK+	TPK+ HIGH TORQUE	SC+	SPC+	TPC+	VH+	VS+	VT+	DP+	HDP+
MF	MF	MA	MF	MF	MF	MF	MF	MF	MF / MA	MA
3	12	66	1	4	4	4	4	4	16	22
100	10000	5500	2	20	20	400	400	400	55	55
≤ 4	≤ 4	≤ 1.3	≤ 4	≤ 4	≤ 4	≤ 3	≤ 3	≤ 3	≤ 3	≤ 1
-	≤ 2	-	-	≤ 2	≤ 2	≤ 2	≤ 2	≤ 2	≤ 1	-

-	-	-	x	x	-	-	x	-	-	-
-	-	-	x	x	-	-	x	-	-	-
-	-	-	-	x	-	-	x	-	-	-
-	-	-	-	x	-	-	-	-	-	-
-	-	-	-	-	-	x	-	-	-	-
-	-	-	-	-	-	x	-	-	-	-
x	-	-	-	-	-	-	-	x	-	-
-	x	x	-	-	x	-	-	-	x	x
-	x	x	-	-	x	-	-	-	-	-
x	x	x	-	-	-	x	x	-	-	-

x	x	x	x	x	x	x	x	x	x	x
-	-	-	-	-	-	-	-	-	-	-

-	-	-	-	-	-	-	-	-	-	-
x	-	-	-	-	-	-	-	-	-	-
x	x	x	x	x	x	x	x	x	x	x
x	x	x	-	-	-	x	x	x	x	x
-	-	-	-	-	-	-	-	-	x	x

x	x	x	x	x	x	-	x	x	-	-
-	-	-	-	-	-	-	-	-	-	-

x	x	x	x	x	x	-	x	x	-	-
-	-	-	-	x	-	x	-	-	-	-

Premium Line gearbox overview



Product type		XP+	XP+ HIGH SPEED	RP+	RP+ HIGH TORQUE	XPK+	RPK+	XPC+	RPC+
Version		MF	MC	MF	MA	MF	MA	MF	MA
Ratio ^{c)}	min. $i =$	3	3	4	5.5	12	48	4	22
	max. $i =$	100	100	10	220	1000	5500	20	55
Max. torsional backlash [arcmin] ^{c)}	Standard	≤ 3	≤ 4	≤ 3	≤ 1	≤ 4	≤ 1.3	≤ 4	≤ 1.3
	Reduced	≤ 1	≤ 2	≤ 1	–	≤ 2	–	≤ 2	–
Output shape									
Smooth shaft		x	x	–	–	x	–	x	–
Shaft with key ^{d)}		x	x	–	–	x	–	x	–
Splined shaft (DIN 5480)		x	x	–	–	x	–	x	–
Blind hollow shaft		x	x	–	–	x	–	x	–
Hollow shaft interface		–	–	–	–	–	–	–	–
Keyed hollow shaft		–	–	–	–	–	–	–	–
Flanged hollow shaft		–	–	–	–	–	–	–	–
Flange		–	–	x	x	–	x	–	x
System output		x	x	x	x	x	x	x	x
Output on both sides		–	–	–	–	–	–	–	–
Input type									
Motor-mounted		x	x	x	x	x	x	x	x
Self-contained version ^{b)}		x	–	–	–	–	–	–	–
Characteristic									
Flange with slotted holes		x	x	x	x	x	x	x	x
ATEX ^{a)}		–	–	–	–	–	–	–	–
Food-grade lubrication ^{a) b)}		x	x	x	x	x	x	x	x
Corrosion resistant ^{a) b)}		–	–	–	–	–	–	–	–
Optimized mass inertia ^{a)}		x	x	x	x	–	–	–	–
System solutions									
Linear system (rack / pinion)		x	x	x	x	x	x	x	x
Servo actuator		x	–	x	x	–	–	–	–
Accessories (please refer to the product pages for further options)									
Coupling		x	x	–	–	x	–	x	–
Shrink disc		x	x	–	–	x	–	x	–

^{a)} Power reduction: technical data available on request

^{b)} Please contact WITTENSTEIN alpha

^{c)} In relation to reference sizes

^{d)} Power reduction: Please use our sizing software cymex® for a detailed sizing – www.wittenstein-cymex.com

Servo actuator overview



Product type		PBG	PAG	PHG	RPM ⁺	TPM ⁺ DYNAMIC	TPM ⁺ HIGH TORQUE	TPM ⁺ POWER	AVF
Version		Standard	Standard	Standard	Customer specific	Standard	Standard	Standard	Standard
Ratio ^{d)}	min. $i =$	16	16	16	22	16	22	4	10
	max. $i =$	100	100	100	220	91	220	100	25
Max. torsional backlash ^{d)} [arcmin]	Standard	≤ 5	≤ 3	≤ 4	≤ 1	≤ 3	≤ 1	≤ 3	≤ 10
	Reduced	≤ 3	≤ 1	≤ 2	–	≤ 1	≤ 1	≤ 1	–
Output shape									
Smooth shaft		x	–	x	–	–	–	–	x
Shaft with key ^{d)}		x	–	x	–	–	–	–	x
Splined shaft (DIN 5480)		x	–	x	–	–	–	–	–
Blind hollow shaft		–	–	–	–	–	–	–	–
Hollow shaft interface		–	–	–	–	–	–	–	–
Keyed hollow shaft		–	–	–	–	–	–	–	–
Flanged hollow shaft		–	–	–	–	–	–	–	–
Flange		–	x	–	x	x	x	x	–
System output		–	x	x	x	x	x	x	–
Output on both sides		–	–	–	–	–	–	–	–
Input type									
Motor-mounted		–	–	–	–	–	–	–	–
Self-contained version		–	–	–	–	–	–	–	–
Characteristic									
Flange with slotted holes		–	–	x	x	–	–	–	–
ATEX ^{a)}		–	–	–	–	–	–	–	–
Food-grade lubrication ^{a) b)}		x	x	x	x	x	x	x	x
Corrosion resistant ^{a) b)}		–	–	–	–	x	x	x	x
Optimized mass Inertia ^{a)}		–	–	–	–	–	–	–	–
System solutions									
Linear system (rack / pinion)		x	x	x	x	x	x	x	–
Accessories (please refer to the product pages for further options)									
Coupling		x	x	–	–	x	x	x	–
Shrink disc		x	–	x	–	–	–	–	–
Power cable, signal cable, hybrid cable		x	x	x	x	x	x	x	x

^{a)} Power reduction: technical data available on request

^{b)} Please contact WITTENSTEIN alpha

^{c)} In relation to reference sizes

^{d)} Power reduction: Please use our sizing software cymex[®] for a detailed sizing – www.wittenstein-cymex.com

WITTENSTEIN alpha Engineering Tools – many ways to reach your goals

Our software portfolio helps you choose the optimal drive

You can conveniently download dimension sheets and CAD data, select the best gearbox quickly and easily design complex kinematic sequences in detail – our software solutions offer various methods of selecting the best, most reliable drive on all axes.



CAD POINT – Your smart catalog

- Performance data, dimension sheets and CAD data for all types of gearboxes
- Available online without logging in
- Comprehensive documentation of the selection

www.wittenstein-cad-point.com

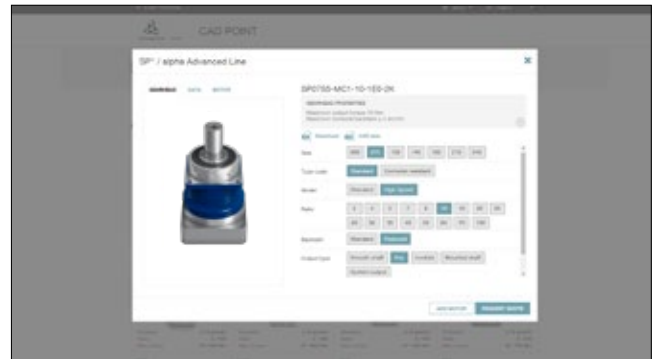

cymex® select – Best solution within seconds

- Efficient and customizable product selection in seconds
- Top three product recommendations for your requirements
- Available online without login
- Possibility of requesting quotation quickly and directly

cymex-select.wittenstein-group.com

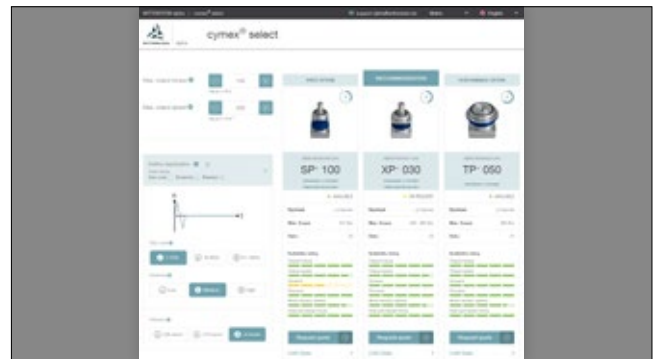

cymex® 5 – Calculate on the Best

- Detailed calculation of complete drive trains
- Precise simulation of motion and load variables
- Downloadable software for complex designs

www.wittenstein-cymex.com



Support at each interaction stage

With the **WITTENSTEIN alpha service concept**, we are also setting new standards in the field of customer support.

DESIGN



We offer the right sizing methodology for every requirement. Whether easy downloading of CAD data, quick and easy calculation, or precise sizing of the drive train.

STARTUP



Our service experts are happy to support you in the installation and startup of complex mechatronic systems, guaranteeing maximum availability of your plant.

SERVICING



WITTENSTEIN alpha guarantees fast repairs of the highest quality and precision. In addition, we will provide you with information about various measurements, material analyses, and condition monitoring inspections.

Consultation

- Personal contact on site
- Competent application calculations and drive sizing

Engineering

Catalog gearboxes:

- Advanced software tools for accurate calculation, simulation, and analysis of the drive train
- Optimization of your productivity

Special gearboxes:

- Development and production of customized gearboxes
- Gearing design and development
- Inquiries: sondergetriebe@wittenstein.de



CAD POINT
YOUR SMART CATALOG



cymex® select
BEST SOLUTION WITHIN SECONDS



cymex® 5
CALCULATE ON THE BEST

speedline® delivery

Tel. +49 7931 493-10444

- Delivery of standard product range in 24 or 48 hours ex works*
- Fast deliveries at short notice

Installation on site

- Professional installation
- Optimal application integration
- Introduction to the operation of the drive

Operating and installation instructions

- Detail description of how to use the product
- Installation and motor mounting videos

* Non-binding delivery time depending on part availability



WITTENSTEIN Service Portal
ONE GATE. ALL SUPPORT.

WITTENSTEIN Service Portal

- Instant Access to Product Information
- Quick Installation and Commissioning for example Tutorial-Videos

Pick-up & return service

- Minimization of downtimes
- Professional logistics organization
- Reduction of transport risks

24 h service hotline

Tel. +49 7931 493-12900

Maintenance and inspection

- Documentation regarding condition and expected service life
- Customer-specific maintenance schedules

Repairs

- Repair to nominal condition
- Immediate response in time-critical situations

cymex® statistics

- Systematic field data acquisition
- Reliability calculations (MTBF)



WITTENSTEIN Service Portal
ONE GATE. ALL SUPPORT.

WITTENSTEIN Service Portal

- Fast Processing of Replacement Products
- The Right Contact for Queries
- Tailor-Made Maintenance Services

Modernization

- Professional retrofitting
- Reliable compatibility testing of existing solutions

The WITTENSTEIN group – The company and its fields of business



WITTENSTEIN

With approximately 2,800 employees worldwide, the WITTENSTEIN group stands for innovation, precision and excellence in the world of mechatronic drive technology, both nationally and internationally. The group is active in six innovative fields of business. Furthermore, WITTENSTEIN group is represented by some 60 subsidiaries in around 40 countries in all important technology and sales markets worldwide.



Our fields of expertise

We provide know-how for a host of different sectors:

- Machine and plant construction
- Software development
- Aerospace
- Automotive & E-mobility
- Energy
- Oil & Gas Exploration and Production
- Medical technology
- Measurement and testing technology
- Nanotechnology
- Simulation

The WITTENSTEIN Group



WITTENSTEIN alpha GmbH
High-precision servo drives and linear systems



WITTENSTEIN cyber motor GmbH
Highly dynamic servo motors and drive electronics



WITTENSTEIN galaxie GmbH
Superior gearboxes and drive systems



WITTENSTEIN motion control GmbH
Drive systems for the most extreme environmental requirements



attocube systems AG
Nanoprecision drive and measurement technology solutions



baramundi software GmbH
Secure management of the IT infrastructure in offices and production



WITTENSTEIN – one with the future

Project planning – servo actuators

Basic design instructions

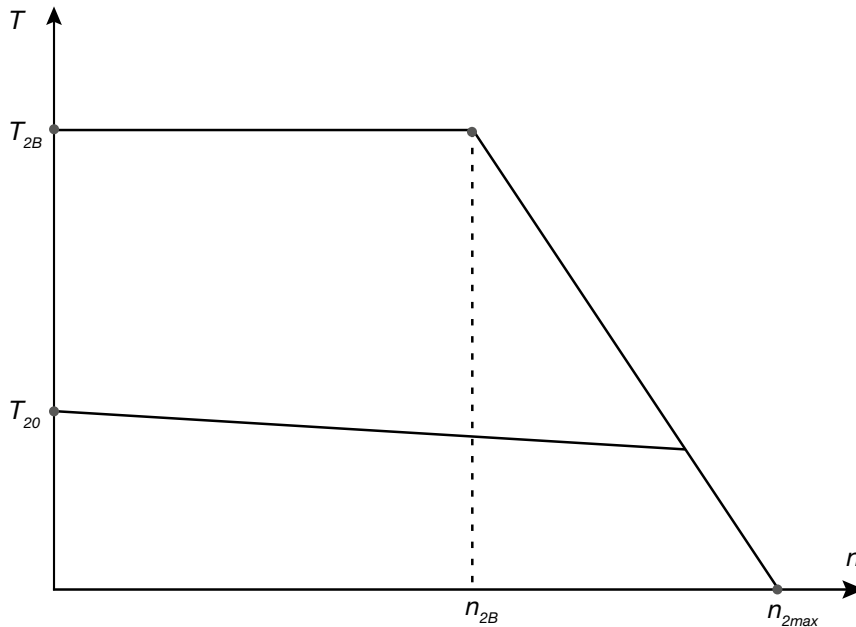

General graph for a servo actuator characteristic curve

To fully utilize the servo actuators, please check the maximum permissible acceleration torques with regard to the following points:

Calculate the maximum acceleration torque required at the gearbox output:

$$T_{2dyn} = \alpha \cdot J_L$$

Identify additional process loads and calculate the total load torque at the gearbox output:

$$T_{2b} = T_{2dyn} + T_{2Pr}$$

Then calculate the total load torque required at the motor:

$$T_{1b} = (\alpha \cdot J_L + T_{2Pr}) \cdot \frac{1}{\eta \cdot i} + \alpha \cdot i \cdot J_1$$

To fully utilize the servo actuator during acceleration, the following conditions must be adhered to:

Condition for the total load torque at the gearbox output:

$$T_{2b} \leq T_{2B}$$

Condition for the total load torque at the motor:

$$T_{1b} \leq T_{Mmax}$$

Project planning note on brakes

The holding brakes used in the servo actuators are subject to various factors, e.g. oxidation of abraded particles, flattening of friction surfaces due to frequent application of the brakes in the same position or air gap changes due to wear.

This may result in a reduction of available holding torques. The specified holding torques, therefore, apply under optimal conditions without detrimental influences. Such influences can be countered by means of a regular brake refresh cycle. For detailed information on the recommended refresh cycles, please refer to our operating manual.

For critical applications, it is recommended to ensure sufficient design safeguards with regard to the holding torque to take the above-mentioned uncertainty factors into account. Our in-house engineering department will be pleased so assist you with the relevant dimensioning.

Depending on the configured transmission ratio, the brakes used in the servo actuators can generate a dynamic brake torque at the output in case of an emergency stop which exceeds the permissible maximum acceleration torque T_{2B} . In this case, the number of dynamic braking operations must be limited to 1,000 during the entire service life of the servo actuator.

Compatibility of servo actuator and servo controller

The axenia value servo actuators can be operated with numerous servo controllers. The following table provides information to assist in selecting the correct options. Please observe the current consumption of the servo actuator during selection of the servo controller used.

Manufacturer	Version/Type	Encoder						Temperature sensor		Operating voltage	
		Resolver	EnDat 2.1	EnDat 2.2	HIPERFACE-CE®	HIPERFACE DSL®	DRIVE-CLiQ	PTC	PT1000	320 V DC	560 V DC
Bosch Rexroth	IndraDrive	x	x	–	x	–	–	x	x	x	x
Beckhoff	AX5000	x	x	x	x	x	–	x	x	x	x
B & R	AcoPos	x	x	x	x	–	–	x	x	(x)	x
Control techniques	UniDrive M	x	x	x	x	–	–	x	x	x	x
Kollmorgen	Servostar 700	x	x	x	x	x	–	x	–	x	x
	AKD	x	x	x	x	x	–	x	x	x	x
Lenze	Global Drive 94xx	x	x	–	x	–	–	x	x	x	x
	TopLine 8400	x	–	–	x	–	–	x	x	x	x
Rockwell	Kinetix 5500	–	–	–	x	x	–	x	–	x	x
	Kinetix 5700	–	–	–	x	x	–	x	–	–	x
	Kinetix 6000	–	–	–	x	–	–	x	–	x	x
	Kinetix 6200	–	–	–	x	–	–	x	–	–	x
	Kinetix 6500	–	–	–	x	–	–	x	–	–	x
Siemens	Sinamics S120	x	x	–	–	–	x	–	x	–	x
Schneider Electric	PacDrive MC-4	–	–	–	x	–	–	x	–	x	x
	PacDrive 3	–	–	–	x	–	–	x	–	x	x

Glossary – alphabetical

Average roughness value (R_a)

The calculated mean value of all deviations of the roughness profile from the mean line of the defined reference section. In the case of hygienic design, it must also be ensured that cleaning is not impaired by any scratches in the surface (maximum roughness).

Characteristic curves 30K and 50K

These characteristic curves show the performance of the servo actuator where the maximum surface temperature is 30 or 50 Kelvin above the ambient temperature. This is especially important in processing operations where personnel come very close to the servo actuators or where sticking of materials getting into contact with the surface should be avoided.

Classification as per DIN EN 1672-2

The standard serves as a basis for hygiene risk reduction and delineation of the classic three zones: Food area, spray area and non-food area. While the food area is characterized by direct food contact with backflow to the food, no backflow can occur in the spray area.

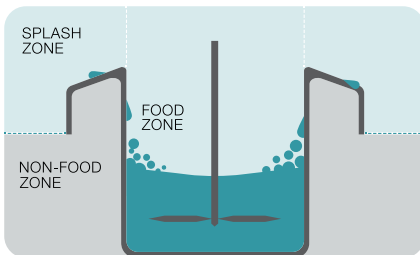

Cleaning-in-Place (CIP)

Cleaning methodology without disassembly of machine parts. Cleaning usually takes place fully automatically and at specified process times and parameters. To prevent aerosol formation, low pressure rather than high pressure is used. SIP processes are an extension.

Degrees of protection (IP)

The various degrees of protection are defined in DIN EN 60529 / DIN EN IEC 60034-5 "Degrees of protection (IP code)". The IP degree of protection (International Protection) is represented by two digits. The first digit indicates the protection against the ingress of impurities and the second the protection against the ingress of water.

Protection against foreign matter and contact	Protection against ingress of water
6 : Full protection against contact and dust-proof	4 : Protection against spray water
	5 : Protection against water jets
	6 : Protection against strong water jets
	7 : Protection against temporary immersion
	9 : Protection against water during high-pressure/steam

European Hygienic Engineering & Design Group (EHEDG)

The main task of the EHEDG is to contribute towards hygienic design and construction in all areas of food production and therefore to ensure the safe processing of foodstuffs.

FDA

The Food and Drug Administration is the U.S. agency responsible for, among other things, the approval, control and monitoring of food and drugs in the United States.

In the field of hygienic design, the focus is on the approval of materials for handling foodstuff in order to avoid contamination through evaporation of plasticizers or spalling of porous materials into the foodstuff, among other things.

Under the Food Safety Modernization Act (FSMA), FDA was granted broader authority and a shift has been initiated away from reactive action and towards preventive hygiene risk considerations in the design and operation of systems.

Hygienic B5 and B14 motor mounting

B5 mounting: Direct screw-fitting by means of through holes in the motor flange into the input flange of the gearbox. Depending on the motor geometry, various drive flanges are available to establish hygienic connections

B14 mounting: With a single hygienic interface, the drive unit is screw-fitted from the side of the gearbox.



Hygienic Design

Cleaning-friendly design based on recognized guidelines and experimental tests. Depending on the area of application, hygienic design is legally binding. Core elements are corrosion-resistant materials, surface roughness of $R_a \leq 0.8 \mu\text{m}$, radii of $r \geq 3 \text{ mm}$, and avoidance of deadspaces, undercuts and horizontal surfaces.

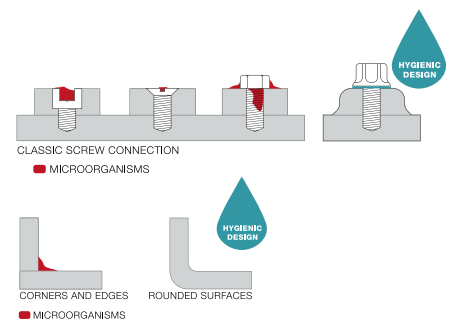

NSF

Lubricants certified as grade H1 by the NSF (National Sanitation Foundation) can be used in the food sector where occasional unavoidable contact with food cannot be excluded.

O-ring forming according to DIN 11864

In components that are not consistently hygienically designed, the O-ring seal is often a weak point. DIN 11864 ensures O-ring design that guarantees fit with a defined pressure and avoids contamination due to thermal expansion and contraction.

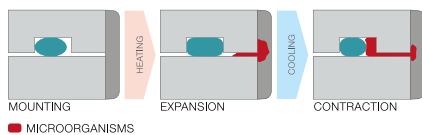

Overall Equipment Effectiveness (OEE)

Indicates the productivity of a system in relation to the possible operating time. The OEE is calculated from the product of three factors: Availability, performance and quality. OEE is expressed as a percentage between 0 and 100%.

Sealing material Fluoroprene

An elastomer for O-rings that has excellent properties. High material resistance to intensive use of aggressive cleaning agents and high temperature range for hot steam sterilization. In addition, the material avoids aroma transfer.

Sealing material PTFE

Polytetrafluoroethylene is a polymer of fluorine and carbon with very resistant properties to aggressive acids and bases, as well as alcohol and gasoline or oil. It has very low friction, so it is excellent as a seal on rotating parts. It is best known under the trade name Teflon from the manufacturer DuPont.

Sealing material TPU

A polyurethane thermoplastic used as a molded seal.

Stainless steel (1.4404 / 316L)

As stainless steel is a collective term, corrosion resistance must always be checked in detail, as not all stainless steels are rust-free and equally resistant. 1.4404, which is frequently used in the food industry, offers significantly better corrosion resistance than 1.4301, for example. In the American notation, 1.4404 is listed as AISI 316L and belongs to the series of V4A steels.

Sterilize-in-Place (SIP)

After CIP cleaning, a SIP process can be run in addition, which kills the last microorganisms with the same devices by means of high-temperature steam and optional addition of disinfectants.

Total Cost of Ownership (TCO)

Consideration of the total costs of a system from planning, acquisition and use to disposal, divided into direct and indirect costs. In addition to the purchase, direct costs also include, for example, energy, installation, service, maintenance and spare parts costs. Production and sales losses, unproductive expenses for difficult cleaning, as well as expenses for training of personnel are among the indirect costs.

Glossary – Formulae

Formulae

Torque [Nm]	$T = J \cdot \alpha$	J = Mass moment of inertia [kgm ² α = Angular acceleration [1/s ²]
Torque [Nm]	$T = F \cdot l$	F = Force [N] l = Lever, length [m]
Acceleration force [N]	$F_b = m \cdot a$	m = Mass [kg] a = Linear acceleration [m/s ²]
Frictional force [N]	$F_{\text{Reib}} = m \cdot g \cdot \mu$	g = Acceleration due to gravity 9.81 m/s ² μ = Coefficient of friction
Angular speed [1/s]	$\omega = 2 \cdot \pi \cdot n / 60$	n = Speed [rpm] π = PI = 3.14...
Linear speed [m/s]	$v = \omega \cdot r$	v = Linear speed [m/s] r = Radius [m]
Linear speed [m/s] (spindle)	$v_{\text{sp}} = \omega \cdot h / (2 \cdot \pi)$	h = Screw pitch [m]
Linear acceleration [m/s²]	$a = v / t_b$	t_b = Acceleration time [s]
Angular acceleration [1/s²]	$\alpha = \omega / t_b$	
Pinion path [mm]	$s = m_n \cdot z \cdot \pi / \cos \beta$	m_n = Normal module [mm] z = Number of teeth [-] β = Helix angle [°]

Conversion table

1 mm	= 0.039 in
1 Nm	= 8.85 in.lb
1 kgcm²	= 8.85 x 10 ⁻⁴ in.lb.s ²
1 N	= 0.225 lb _f
1 kg	= 2.21 lb _m

Sign

Sign	Unit	Designation
a	m/s ²	Linear acceleration
C	Nm/arcmin	Rigidity
ED	%, min	Duty cycle
F	N	Force
f_s	–	Shock factor
f_e	–	Factor for duty cycle
h	m	Ball screw pitch
i	–	Ratio
I	A _{eff}	Effective current
j_t	arcmin	Backlash
J	kgm ²	Mass moment of inertia
$K1$	Nm	Factor for bearing calculation
L	h	Service life
L_{PA}	dB(A)	Operating noise
l	m	(Lever) length
m	kg	Weight
m_n	mm	Normal module
M	Nm	Torque
n	min ⁻¹	Speed
p	–	Exponent for bearing calculation
P	W	Power
r	m	Radius
s	m	Dist.
t	s	Time
T	Nm	Torque
v	m/min	Linear speed
z	1/h	Number of cycles
α	rad/s ²	Angular acceleration
β	°	Helix angle
η	%	Efficiency
λ	-	Ratio of mass moment of inertia, coupling factor
μ	-	Coefficient of friction
ω	rad/s	Angular speed

Index

Index	Designation
Capital letter	Permissible values
Small letter	Actual values
1	Input
2	Output
A/a	axial
out	Output side
B/b	Acceleration
c	constant
d	Delay
dyn	dynamic
e	Pause
in	Input side
ext	External
h	Hour(s)
int	Internal
K/k	Tilting
L	Load. load side
m	moderate
Max./max.	maximum
M, Mot	Motor
N	Nominal
Not/not	EMERGENCY OFF
0	No load
opt	Optimized
Pr	Process side
Q/q	Lateral
Reib	Friction
stat	Stationary
t	Torsional
T	Tangential
Total	Total, overall
verl	Loss



alpha

WITTENSTEIN alpha GmbH
Walter-Wittenstein-Straße 1
97999 Igersheim
Germany

Tel. +49 7931 493-0
24h-Service-Hotline: Tel. +49 7931 493-12900
speedline®: Tel. +49 7931 493-10444
info@wittenstein-alpha.com

Subject to technical changes.

WITTENSTEIN alpha – Intelligent drive systems

www.wittenstein-alpha.com

The entire world of drive technology – Catalogs available on request or online at www.wittenstein-alpha.com/download/catalogs



alpha Premium Line. Unique, individual solutions that offer unparalleled power density.



alpha Advanced Line. Maximum power density and outstanding positioning accuracy for complex applications.



alpha Basic Line & alpha Value Line. Reliable, flexible and economical solutions for a wide range of applications.



alpha Linear Systems. Precise, dynamic system solutions for every requirement.



alpha Mechatronic Systems. Energy-efficient, versatile and flexible mechatronic drive systems.



alpha Accessories. Optimally designed and adapted for gearboxes and actuators.